

CHANNEL VISION Limited Warranty

Channel Vision Technology will repair or replace any defect in material or workmanship which occurs during normal use of this product with new or rebuilt parts, free of charge in the USA, for two years from the date of original purchase. This is a no hassle warranty with no mail in warranty card needed. This warranty does not cover damages in shipment, failures caused by other products not supplied by Channel Vision Technology, or failures due to accident, misuse, abuse, or alteration of the equipment. This warranty is extended only to the original purchaser, and a purchase receipt, invoice, or other proof of original purchase date will be required before warranty repairs are provided.

Mail in service can be obtained during the warranty period by calling (800) 840-0288 toll free. A Return Authorization number must be obtained in advance and can be marked on the outside of the shipping carton.

This warranty gives you specific legal rights and you may have other rights (which vary from state to state). If a problem with this product develops during or after the warranty period, please contact Channel Vision Technology, your dealer or any factory-authorized service center.

CHANNEL VISION™

Model IW801

8" In-wall Speaker

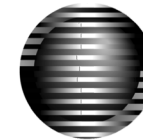
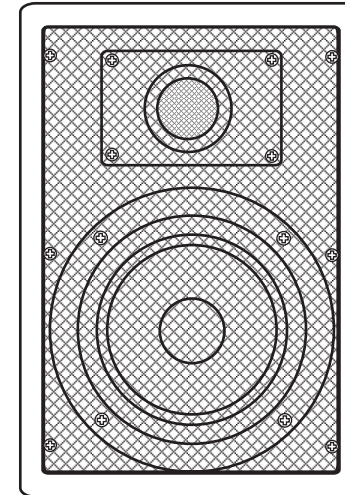

CHANNEL VISION™

234 FISCHER AVENUE • COSTA MESA, CA 92626
(714) 424-6500 • (800) 840-0288 • (714) 424-6510 fax
www.channelvision.com • email: sales@channelvision.com

Model IW801

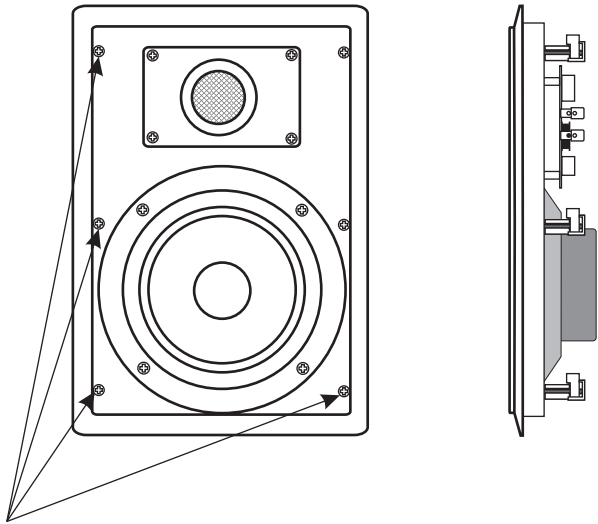

Mounting screws (6)

Installation:

- Use the included template to mark and cut a hole in the drywall.
- We recommend wiring with AWG 16 or larger, stranded wire.
- For proper phasing, all speakers in the system must be wired alike. Connect red wires to red terminals on speaker and to red or plus terminals on amplifier.
- Install the IW801 in the hole. Tighten the mounting screws. The mounting dogs will rotate outward and grip the drywall.
- Aim tweeter

Features:

High power handling capacity

2nd order crossover 12dB per octave with poly switch for tweeter protection.

8" polypropylene woofer with butyl rubber surround

1" pivoting soft dome tweeter

Gold speaker terminals

Small perforated designer grille

Mounting template and paint shield included (rough-in bracket sold separately model: IW80B)

Recommended power: 20W to 100W

Specifications:

Frequency range: 35Hz - 20kHz \pm 3dB

Sensitivity: 90dB (1W/1m)

Power Handling: 175-Watts Peak

Drivers:
1- 1" soft dome tweeter
1- 8" polypropylene woofer

Impedance: 8 ohms

Finish: ABS plastic

Dimensions: 13.88"H x 10.128"W x 3.44"D
(from surface of wall board)

Specifications subject to change without notice.