

 **CHANNEL VISION™**
10 Year Limited Warranty

Channel Vision Technology will repair or replace any defect in material or workmanship which occurs during normal use of this product with new or rebuilt parts, free of charge in the USA, for ten years from the date of original purchase. This is a no hassle warranty with no mail in warranty card needed. This warranty does not cover damages in shipment, failures caused by other products not supplied by Channel Vision Technology, or failures due to accident, misuse, abuse, or alteration of the equipment. This warranty is extended only to the original purchaser, and a purchase receipt, invoice, or other proof of original purchase date will be required before warranty repairs are provided.

Mail in service can be obtained during the warranty period by calling (800) 840-0288 toll free. A Return Authorization number must be obtained in advance and can be marked on the outside of the shipping carton.

This warranty gives you specific legal rights and you may have other rights (which vary from state to state). If a problem with this product develops during or after the warranty period, please contact Channel Vision Technology, your dealer or any factory-authorized service center.

 **CHANNEL VISION™**
channelvision.com

234 Fischer Avenue, Costa Mesa, California 92626
(714)424-6500 • (800)840-0288 • (714)424-6510 fax

500-044 RevB1

INSTRUCTIONS

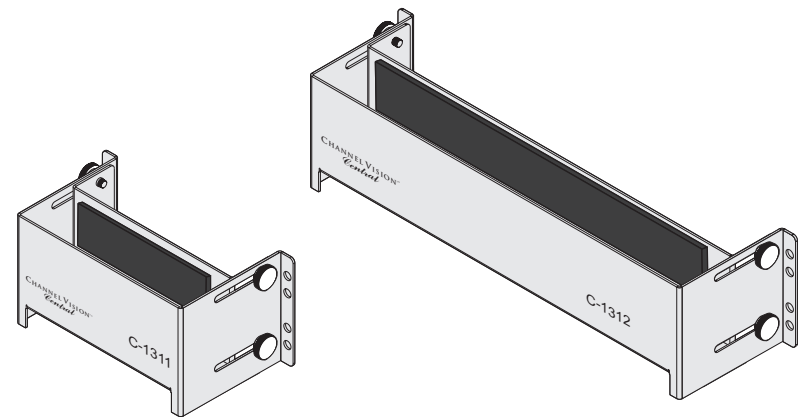

C-1311 & C-1312 **Universal Product Holders**

 **CHANNEL VISION™**
CENTRAL

©2005 CHANNEL VISION TECHNOLOGY

The **C-1311** and **C-1312** are universal product holders which can be used to mount a variety of products inside the Channel Vision Central structured wiring enclosure.

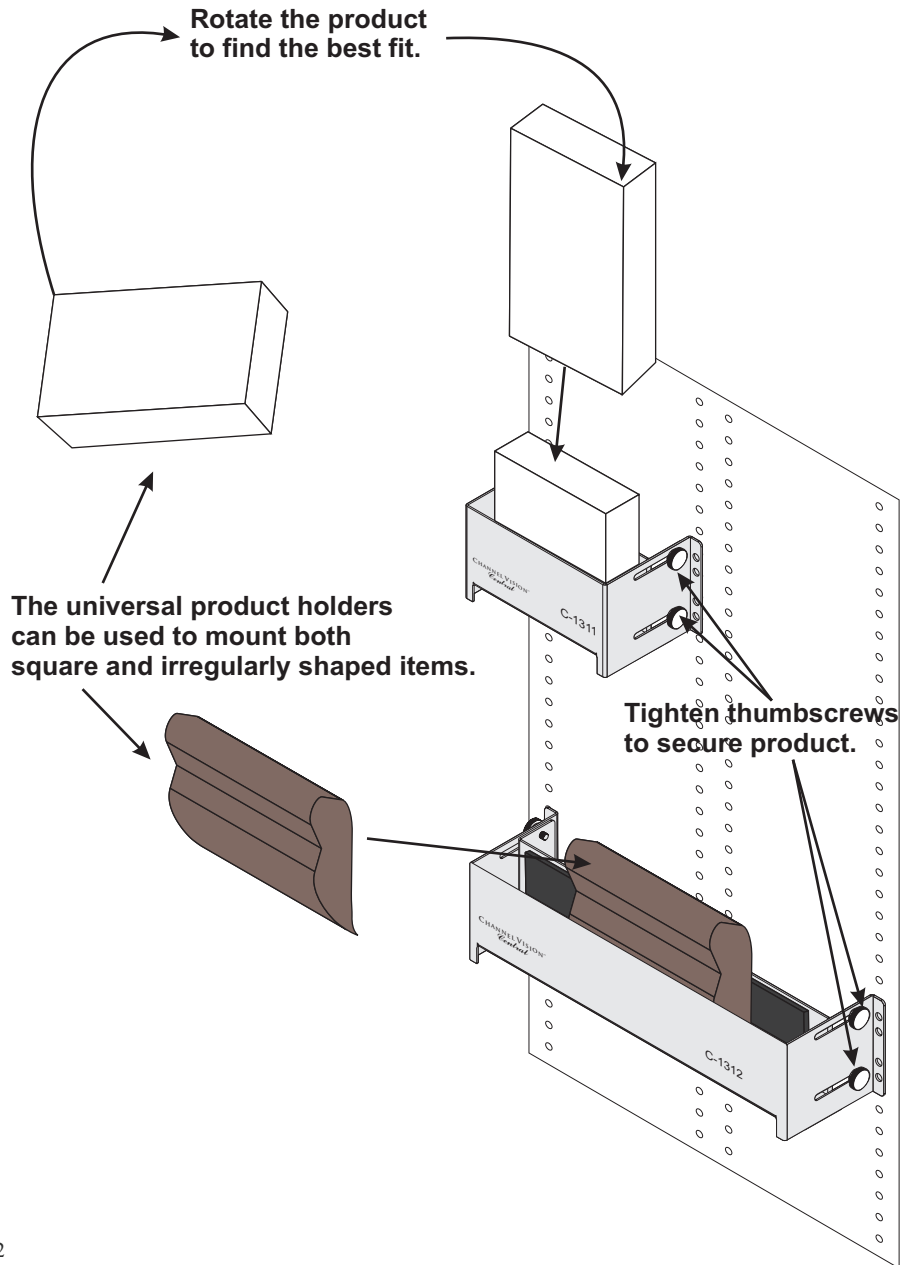

Making adjustments

