

# Channel Vision Limited Warranty

Channel Vision Technology will repair or replace any defect in material or workmanship which occur during normal use of this product with new or rebuilt parts, free of charge in the USA, for two years from the date of original purchase. This warranty does not cover damages in shipment, failures caused by other products not supplied by Channel Vision Technology, or failures due to accident, misuse, abuse, or alteration of the equipment. This warranty extends only to the original purchaser. A purchase receipt, invoice, or other proof of original purchase date will be required before warranty repairs are provided.

Mail in service can be obtained during the warranty period by calling toll free (714) 424-6500. A Return Authorization number must be obtained in advance and be marked on the outside of the shipping carton.

This warranty gives you specific legal rights, and you may have other rights which vary from state to state. If a problem with this product develops during or after the warranty period, please contact Channel Vision, your dealer, or any factory-authorized service center.



CHANNEL VISION™

Central

**C-0314**

**8dB RF Amplified Splitter**

## Description

Channel Vision's 8dB power injected amplifier increases the strength of the incoming cable or antenna signal. The increased signal strength means that you can distribute the television signal longer distances and to more outputs. Unlike most RF amplifiers, the C-0314 uses an external power supply that can be connected directly to the unit using a coax "F" connector. For added versatility the power injection feature was removed so we could pass IR.

**Standard Wiring Layout**

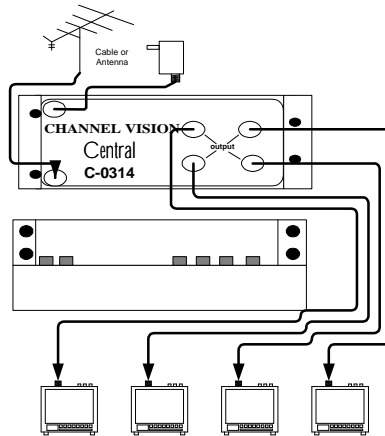

## Instructions

- Step 1:** Snap the C-0314 into C-0112, C-0119, C-0138, C-0150 chassis of your choice.
- Step 2:** Connect the incoming cable or antenna line to the INPUT port.
- Step 3:** Connect the outgoing coax cable to the OUTPUT port to distribute the signal to 4 TV locations or a passive splitter.
- Step 4:** Connect the power transformer to the DC12V INPUT.

## Please Note:

The unused trunk line connector or unused output of the last outlet device in each trunk line **MUST BE TERMINATED** using a 75Ω terminator (*model 2101*).

## Specifications

Bandwidth	45-1000Mhz
Gain	8dB +/-1.5
Flatness	+/-1dB
Return Loss (min)	14dB
Return	5-42Mhz
Dist. X-Mod.	-70dB
CTB	-65dB
Power Supply	12V/55mA

## Warning

To prevent fire or shock hazard, do not expose this appliance to rain or moisture