

INSTRUCTIONS

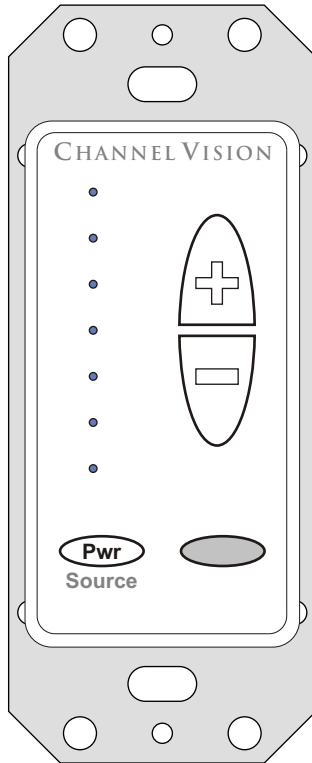

A0125 **Multi-Source Volume Control Keypad**

● CHANNEL VISION™

©2008 CHANNEL VISION TECHNOLOGY

The **A0125** is a volume control keypad for Channel Vision's single-source and multi-source CAT5 audio systems. It provides convenient volume control and source selection capabilities, while its elegant decorator styling blends seamlessly with other wall switch devices.

Features:

- Compatible with P-2014 and P-2044
- Supports IR control: compatible with the A0501, A0502, and A0505 remote controls
- LEDs show volume level or source selection
- Works at CAT5 lengths up to 300 feet

LED Indicators ... Can show volume level or source selection.

Top LED Indicator ... Flashes when IR signals are received.

Volume Controls...
Increase or decrease volume level.

IR Window...
Receives signals from IR remote controls.

Pwr/Source Button ... Keypad On/Off control and source selection control when in multi-mode.

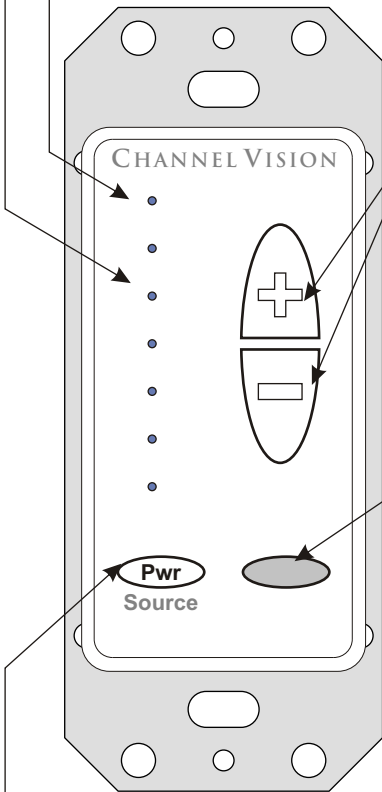

How it Works

The A0125 can be used in two different modes: 1) single source mode, 2) multi-source mode. Mode selection is controlled by a jumper setting prior to installation. When using the A0125 with a single-source CAT5 audio hub, it should be set for the single-source mode. In this mode, the unit provides basic controls: volume up, volume down, and power on/off. When using it with a multi-source CAT5 audio matrix, it should be set for multi-source mode. In this mode, any zone can independently select and listen to any source at any time. Source selection can be done either from the A0125 amplified keypad or by using the A0501, A0502, or A0505 remote control.

Basic Operation

Using the A0125 Volume Control Keypad...

The Pwr (power) button located at the lower left of the keypad is used for source selection and to turn the unit on or off. When in single-source mode, press and release the Pwr button to toggle the keypad on or off. When in multi-source mode, if the keypad is off, press and release Pwr to turn it on. Press Pwr again to see the current source selection and press repeatedly to scroll through the 4 sources. Press and hold the power button to turn the keypad off. While the keypad is off, press and hold the power button again to turn off the zone output of the P-2044.

As you change sources when in multi-mode, you'll notice that the top 4 LEDs illuminate corresponding to the source you have selected. When source one is selected, the first LED is illuminated, when source two is selected, the second LED is illuminated, and so on.

When the A0125's Intercom jumper is set to the INTERCOM position, the keypad will react to intercom events by flashing the Pwr LED and changing the volume level to the preset intercom volume level. For more details see the section titled: Jumper Settings.

After a source is selected the LED will stay lit for 5 seconds, then it will return to showing the current volume level.

Volume adjustments can be made using the up/down buttons to the right hand side of the keypad. The keypad can be controlled from the A0505 remote control (see the section titled: Using the A0505 remote control for more details).

- These four LEDs illuminate to indicate which source input is selected.
- The Pwr button is used for source selection.

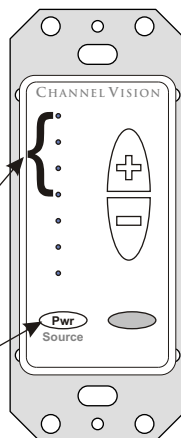

Jumper Settings

Jumper settings determine how the A0125 will react under various circumstances. These jumpers should be set to the desired configuration before the A0125 is installed. If you need to make changes to the jumper settings, the A0125 MUST BE DISCONNECTED from the system first.

Jumper setting functions explained:

Volume Preset - This jumper determines the volume level the keypad will be for music (no affect on the Intercom audio level) when it is turned on. If the jumper is on pins 1 & 2, the volume will always be set at the default level when the A0125 is turned on. If the jumper is on pins 2 & 3, the volume will be at the same level as it was before the A0125 was turned off.

Status Active - This jumper is not active at this time on the A0125.

Source Mode - This jumper determines if the A0125 will be used as a multi-source keypad or a single-source keypad. If you are using the keypad in a single source system, set the jumper on pins 1 & 2. If you are using the keypad in a multi-source system, set the jumper on pins 2 & 3.

Intercom - This jumper tells the keypad that it is connected to a hub with integrated intercom functions. When in intercom mode, an intercom event will cause the pwr LED to flash and the volume will change to its alternate intercom volume level. While the pwr LED is flashing, volume changes on the A0125 will alter the intercom volume level, which is independent of the audio volume level.

Jumper Function	Jumper on Pins 1 & 2	Jumper on Pins 2 & 3
Volume Level	Default volume level	Previous volume level
Status Active	(Not Used)	(Not Used)
Source Mode	Single-Source	Multi-Source
Intercom	Intercom	No Intercom

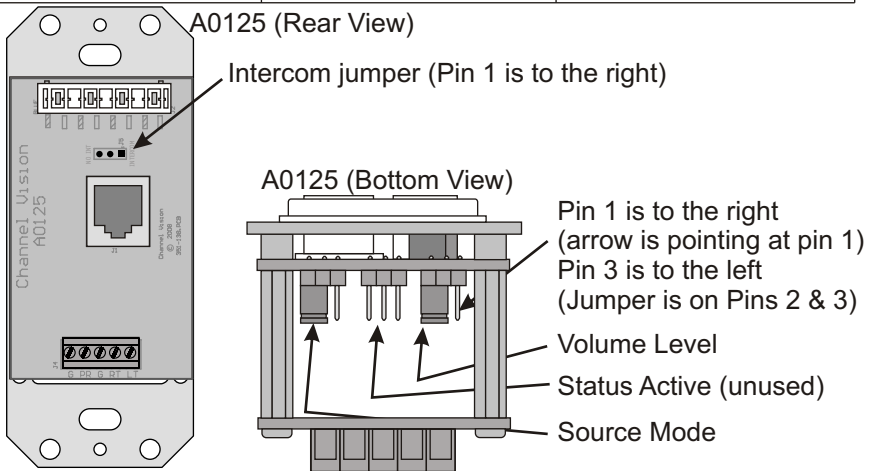

Installation

A0125 (Rear View)

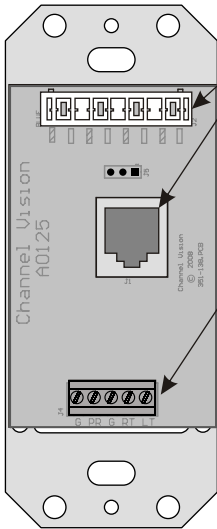

Input Connectors ... To simplify installation, the A0125 has both 110 and RJ-45 inputs. Only one of the inputs should be used at a time.

Output Connector ... This 5 position screw terminal is used to connect line level audio out to the A0302 where it can be delivered to the A0240 for amplification. The Ground (G) and Power (PR) terminals can be used to accept power from the A0240 via the A0302. These terminals should only be used if the A0125 is not connected to one of Channel Vision's CAT5 audio hubs.

Connect the A0125 to one of Channel Vision's CAT5 Audio Hubs. The CAT5 Audio Hub will distribute line level audio and power to the A0125.

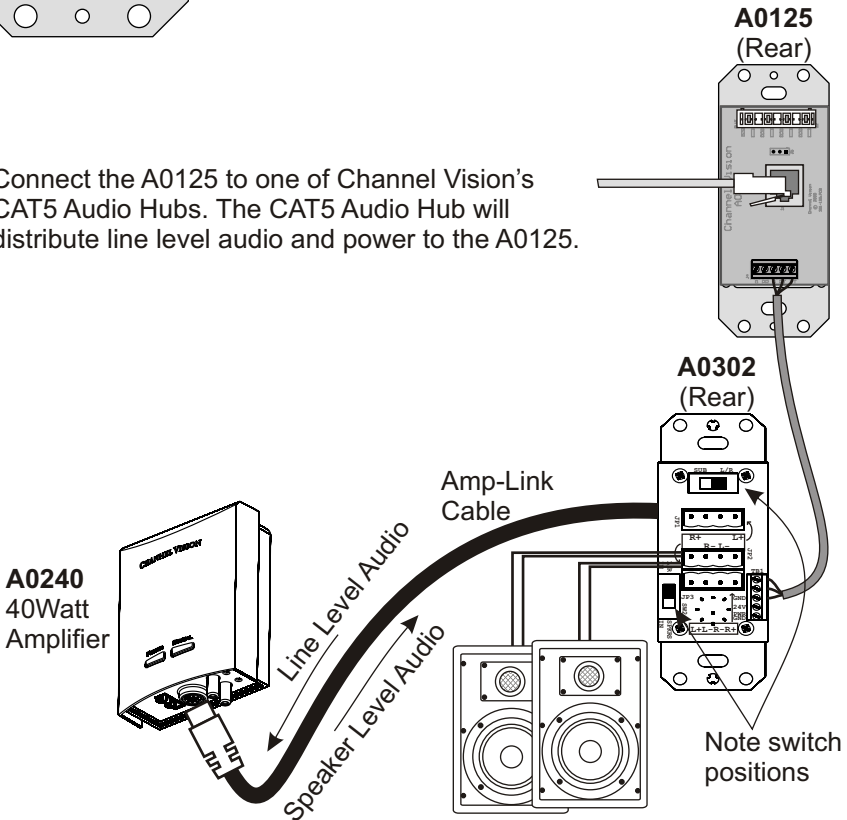

Single-Source System

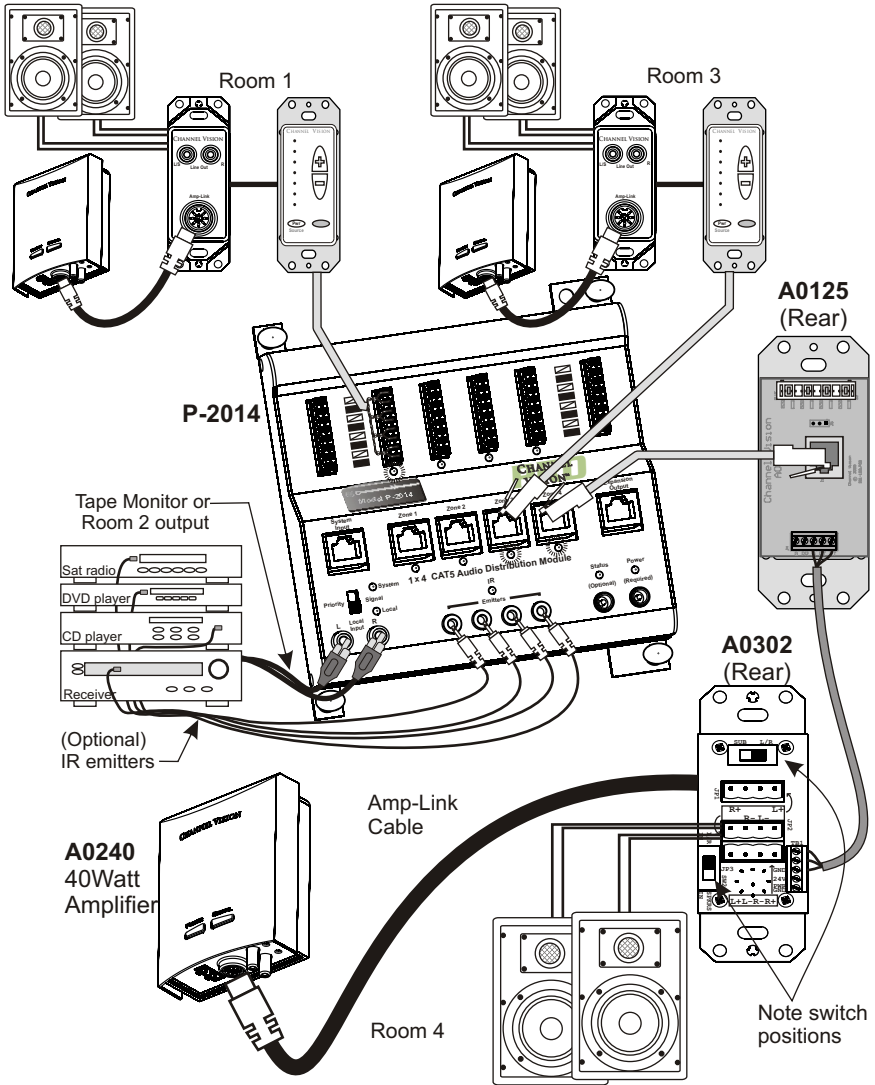

When using the A0125 with a single-source CAT5 audio hub, the source mode jumper should be set for single-source. In this mode, the source selection features are not available. Pressing the Pwr button will turn off the keypad, but other keypads will continue to play.

Multi-Source Application

When using the A0125 in a multi-source system with the P-2044, the source mode jumper should be set for multi-source. In this mode, the source selection features are enabled allowing any zone to independently select and listen to any source at any time.

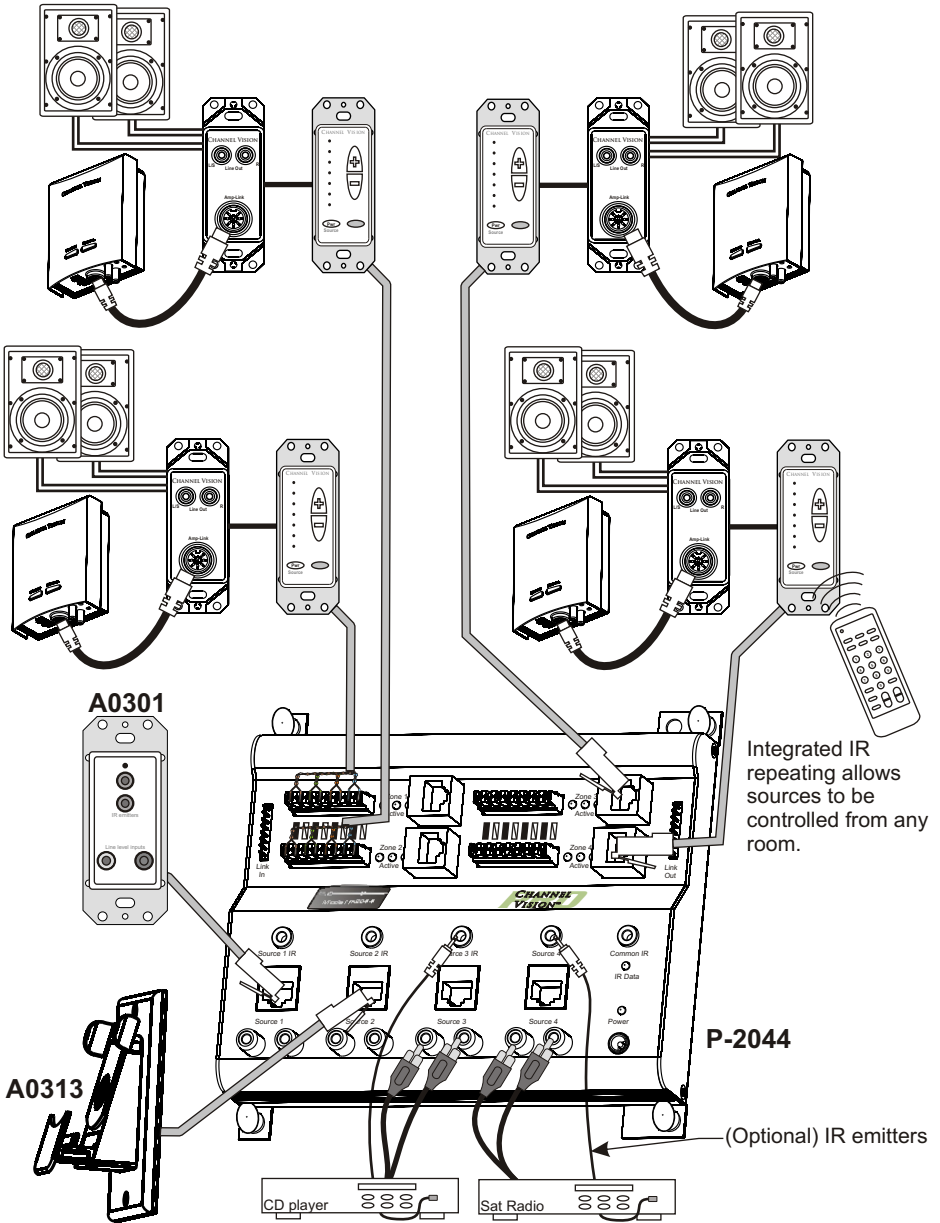

Using the A0505 Remote Control

Using the A0505 remote control...

The A0505 is designed to allow you to control your P-2044 without having to touch the buttons on the A0125. Simply point the A0505 remote control at the IR sensor located at the bottom of the A0125 and press the desired button.

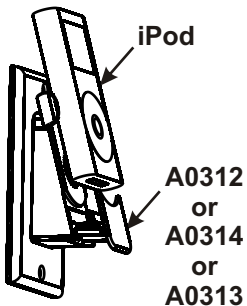
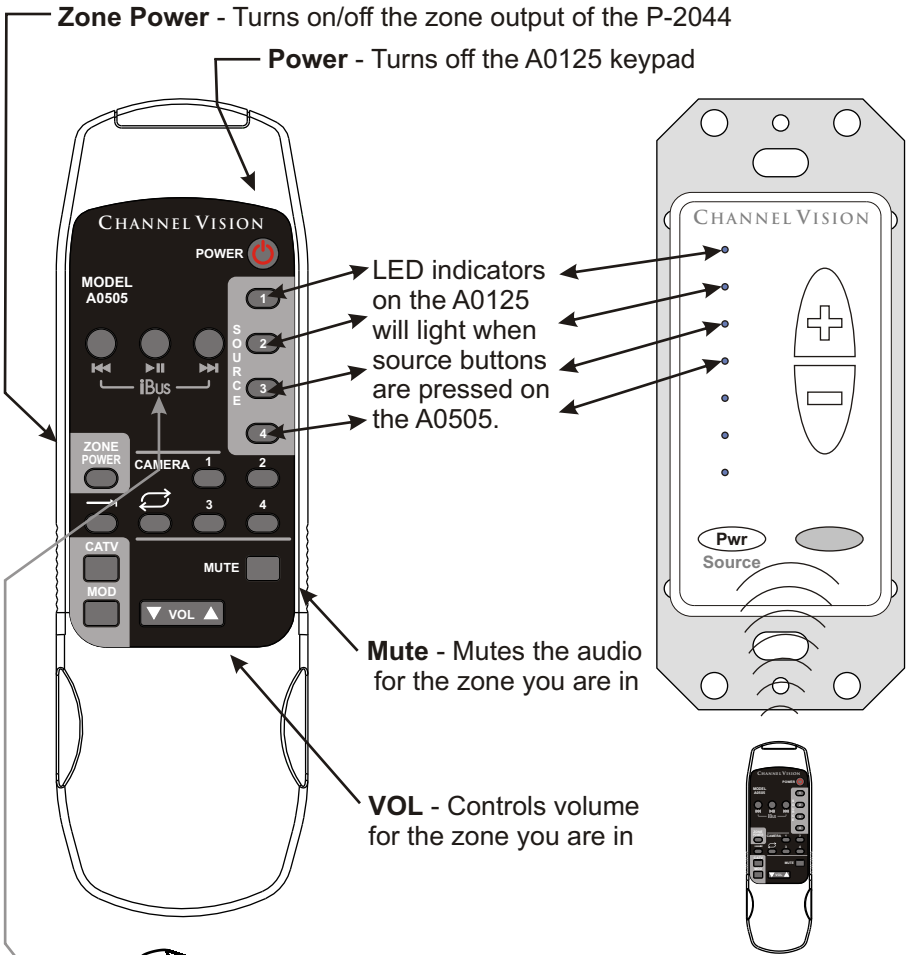

Using the A0505 remote with iBus...

Your iPod's shuttle controls can be operated from the A0505 when it is docked in a compatible iBus wall station.

Creating Sub-Zones

The single-source CAT5 audio hub (model P-2014) can be integrated together with the multi-source CAT5 audio matrix (model P-2044). The keypads connected to the P-2014 will act as sub-zones to the P-2044. These sub-zones will all play the same audio which is perfect for common areas such as hallways, bathrooms, kitchen, or dining room. For this kind of system, all of the A0125 keypads should be configured for multi-mode.

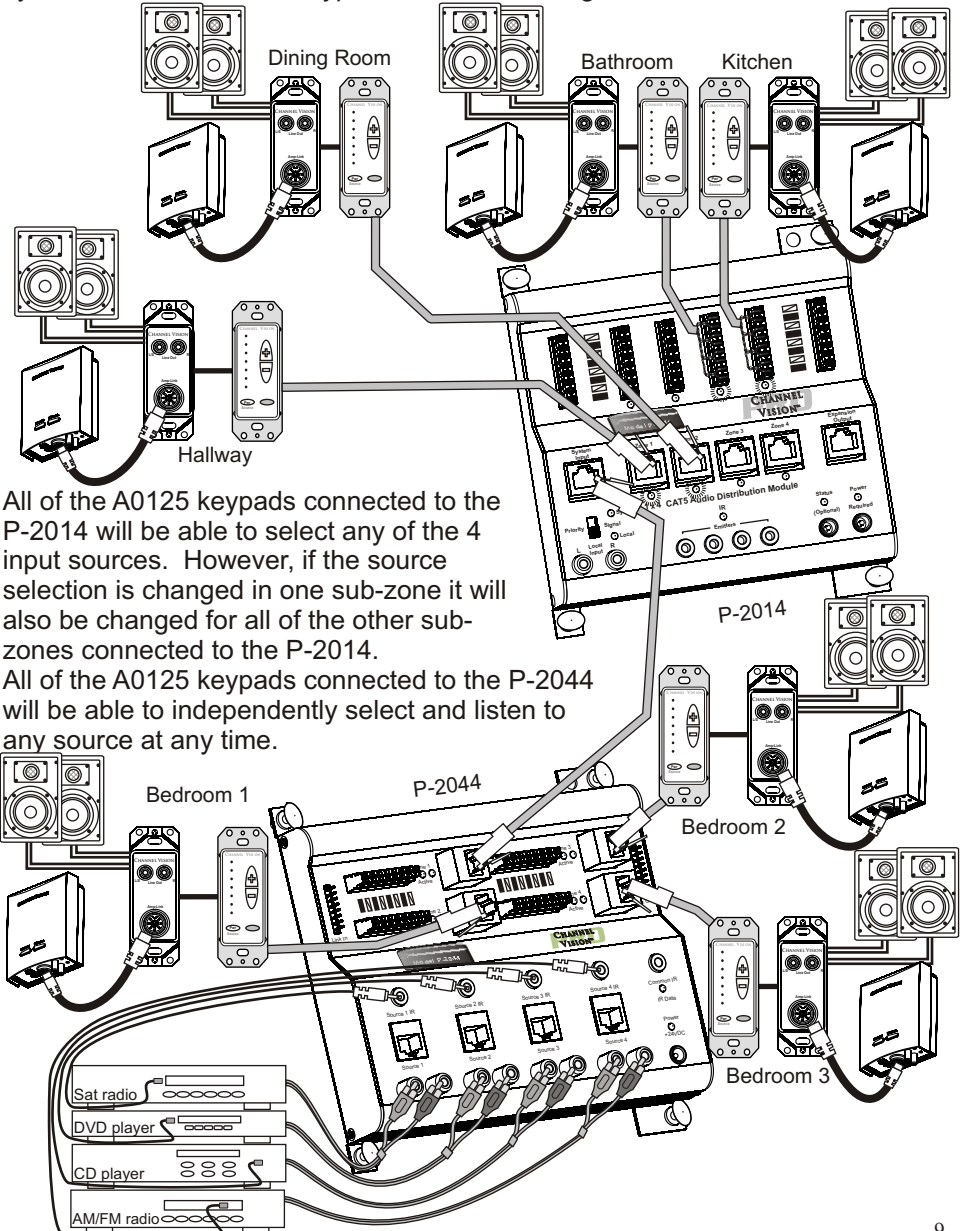

Connection Tips and Troubleshooting

- 1) Be sure you have connected the CAT5 cable correctly. Follow the TIA-568A standard at both ends. Mis-wiring can cause distorted sound or prevent the system from working at all!
- 2) Be sure you have connected the speakers in phase. Follow the label on the product. Out of phase speakers can rob the system of its bass, especially when driving dual-voice-coil speakers.
- 3) Trouble with IR control?
 - a. Make sure you are using the correct remote control. The A0125 will respond to IR signals from the A0501, A0502, and A0505 remotes produced by Channel Vision. These remotes can provide both volume control and source selection commands. Other 3rd party remote controls that are capable of learning the IR codes from the remote controls listed above can also be used.
 - b. The top LED on the A0125 acts as an IR receiver feedback LED that flashes whenever IR signals are received. Check to make sure the LED flashes whenever you press buttons on your remote control. If you don't see the feedback LED, try replacing the batteries in your remote control.
 - c. Try adjusting the placement of your IR emitters. If they are placed directly over the sensor on the device you are trying to control, try moving them a short distance away from the sensor.
- 4) If no audio is heard, check to make sure that the audio source is playing, then press the power button on the A0125 to make sure it is turned on.
 - a. There may be something wrong with the CAT5 audio hub. Some Channel Vision audio hubs provide LED indicators to show which zones are connected and active. Review these LEDs and refer to the instruction manual for your specific audio hub.
- 5) Observe wiring distance specifications. The maximum recommended wire length between the audio hub output and A0125 is 300 feet. Although the A0125 can work at greater distances, such extreme distances are not recommended because degraded performance may result due to signal loss caused by longer CAT5 wire runs.
- 6) If you need additional help troubleshooting the A0125 please contact Channel Vision technical support (1-800-840-0288) or check our website for more details: www.channelvision.com.

Stripping and Connecting CAT5 Wire

CAT5 cable should be stripped with a proper stripping tool, such as Channel Vision's J-110 tool.

1. Place the CAT5 between the blade and the first notch of the J-110 tool.

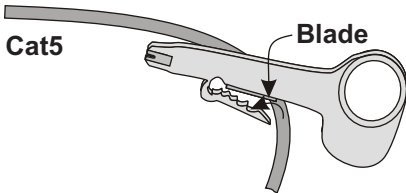

2. Rotate the tool only once. Multiple turns will cause you to cut into the inner wires.

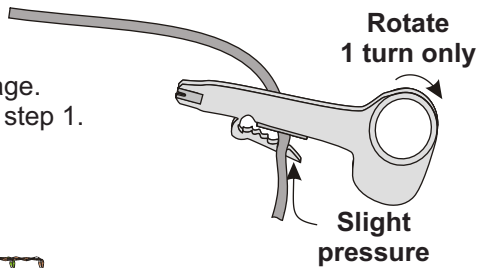

3. Inspect the inner wires for damage. If any wires are cut start over at step 1.

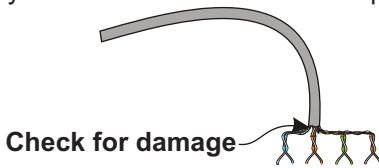

TIA-568A RJ-45 Modular Plug

Side view:

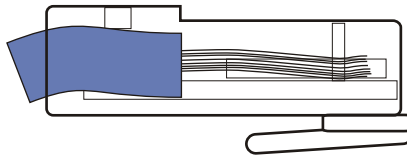

Top view:

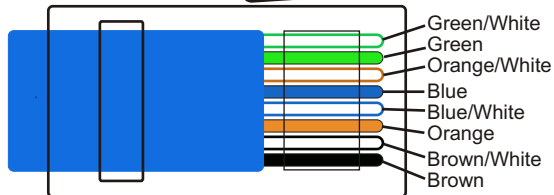

Specifications: (typical @25° C)

Operating Voltage :	18VDC
Cable requirements:	CAT5 or better
Max wire length:	300 ft.
IR repeating:	30-60kHz
IR sensor range:	40'@40kHz, 25'@56kHz
Operating Temperature:	-10°C to +50°C

Specifications subject to change without notice.



2 Year Limited Warranty

Channel Vision Technology will repair or replace any defect in material or workmanship which occurs during normal use of this product with new or rebuilt parts, free of charge in the USA, for two years from the date of original purchase. This is a no hassle warranty with no mail in warranty card needed. This warranty does not cover damages in shipment, failures caused by other products not supplied by Channel Vision Technology, or failures due to accident, misuse, abuse, or alteration of the equipment. This warranty is extended only to the original purchaser, and a purchase receipt, invoice, or other proof of original purchase date will be required before warranty repairs are provided.

Mail in service can be obtained during the warranty period by calling (800) 840-0288 toll free. A Return Authorization number must be obtained in advance and can be marked on the outside of the shipping carton.

This warranty gives you specific legal rights and you may have other rights (which vary from state to state). If a problem with this product develops during or after the warranty period, please contact Channel Vision Technology, your dealer or any factory-authorized service center.



www.channelvision.com

234 Fischer Avenue, Costa Mesa, California 92626 USA

(714)424-6500 • (800)840-0288 • (714)424-6510 fax

email: techsupport@channelvision.com