

INSTRUCTIONS



6521

Dome Color Megapixel IP Camera w/IR Illuminators

6522

Bullet Color Megapixel IP Camera w/IR Illuminators

Table Of Contents

Model Info	Page 3
Warnings	Page 4
Cable Pin Out	Page 5
Power Over Ethernet	Page 6
Assigning An IP Address	Page 7
Assigning An IP Address continued	Page 8
Assigning An IP Address continued	Page 9
Assigning An IP Address continued	Page 10
Connecting Your Camera	Page 11
Installing The ActiveX Control	Page 11
Configuring Internet Explorer	Page 12
Live Viewing	Page 13
Live Viewing continued	Page 14
Configuration	Page 15
System Configuration	Page 16
User Management	Page 17
System Update	Page 18
Network	Page 19
Network continued	Page 20
Network continued	Page 21
Network continued	Page 22
Video Settings	Page 23
Video Settings continued	Page 24
Video Settings continued	Page 25
Video Settings continued	Page 26
Video Settings continued	Page 27
Video Settings continued	Page 28
Video Settings continued	Page 29
Recommended Video Settings	Page 30
Recommended Video Settings/Cont	Page 31
Audio	Page 32
Audio continued	Page 33
Event List	Page 34
Event List continued	Page 35
Schedule	Page 36
I/O Setting	Page 37
I/O Setting continued	Page 38
SD Card (6521 only)	Page 39
Port Forwarding Example	Page 40
6521 Specifications	Page 41
6522 Specifications	Page 42
Warranty Statement	Page 43

Models 6521/6522

The 6521 & 6522 are 2 Megapixel bullet and dome CMOS IP cameras.

- Built-in web server, allows users to view high quality, real-time video with the Internet Explorer browser.
- Uses H.264, MJPEG and MPEG4 codecs
- Live video can be recorded to a computer and played back remotely, as well as viewed from many mobile phones and other devices.
- Designed for large commercial projects with 100's of cameras or a single family house requiring a camera at the front door.

6521 Features:

Channel Vision's 6521 Vandal Proof IP Dome offers superior image quality with a 2 megapixel CMOS sensor and has the ability to capture images up to UXVGA (1600 x 1200 pixels). With H.264 compression, less bandwidth and storage space are used, while delivering full resolution at max frame rate with faster speeds over the internet. The 6521 also features event triggered SD card recording, as well as 18 IR LED for a viewing distance of 50 feet in total darkness. Monitoring can be done anywhere an internet connection is available even from a 3G Smart-phone

6522 Features:

Channel Vision's 6521 Vandal Proof IP Dome offers superior image quality with a 2 megapixel CMOS sensor and has the ability to capture images up to UXVGA (1600 x 1200 pixels). With H.264 compression, less bandwidth and storage space are used, while delivering full resolution at max frame rate with faster speeds over the internet. The 6522 has a varifocal lens with built-in 35 IR LED for a viewing distance of 60 feet in total darkness. Monitoring can be done anywhere an internet connection is available even from a 3G Smart-phone

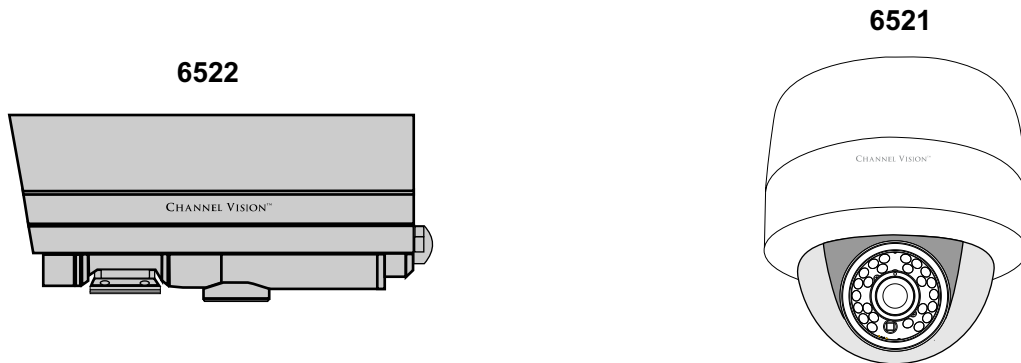



Warnings

WARNINGS

TO REDUCE THE RISK OF FIRE OR ELECTRIC SHOCK, DO NOT EXPOSE THIS PRODUCT TO RAIN OR MOISTURE.

DO NOT INSERT ANY METALLIC OBJECT THROUGH VENTILATION GRILLS.

	CAUTION	
	RISK OF ELECTRIC SHOCK DO NOT OPEN	
CAUTION : TO REDUCE THE RISK OF ELECTRIC SHOCK. DO NOT REMOVE COVER (OR BACK). NO USER-SERVICEABLE PARTS INSIDE. REFER SERVICING TO QUALIFIED SERVICE PERSONNEL.		

COPYRIGHT

ALL TRADEMARKS MENTIONED IN THE MANUAL ARE LEGALLY REGISTERED TO THEIR RESPECTIVE COMPANIES.

Cable Pin Out

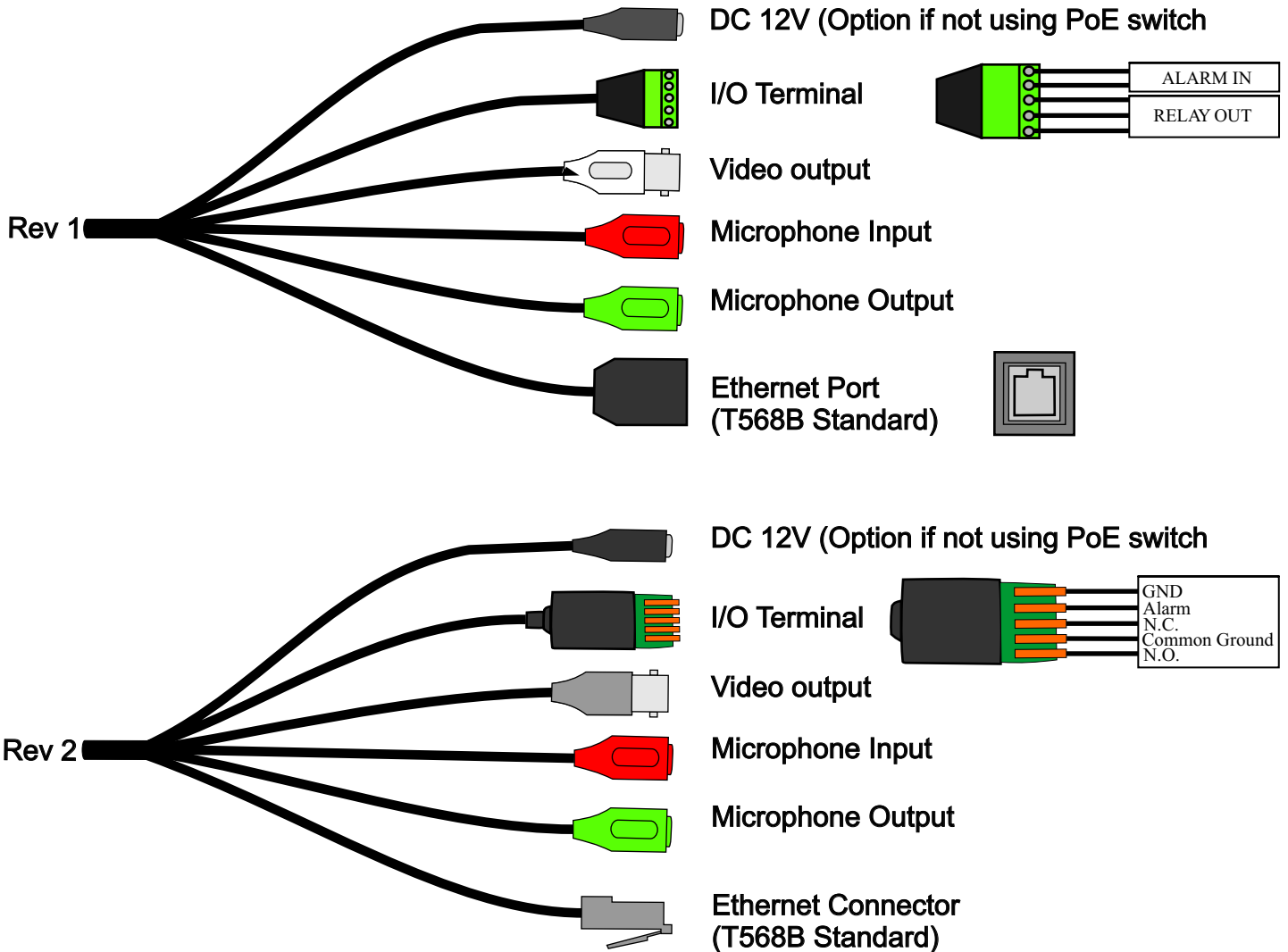

WARNING

DO NOT CUT THE BREAKOUT CABLE.
CUTTING THE CABLE WILL VOID THE WARRANTY ON THE DEVICE.
 Channel Vision will still provide technical support if the cable is cut,
 but cannot guarantee functionality.

The breakout cable on Channel Vision's IP Cameras are used for motion detection, event triggering, alarm notifications etc.
 The provided interface connections are explained below.

1.) Digital Input (GND+Alarm):

An alarm input for connecting devices that can toggle between an open and closed circuit, for example PIRs, door/window contacts, broken glass detectors, etc. When a signal is received, the state changes and the input becomes active.

2.) Relay output (COM +N.O.) / (COM+N.C.)

A selectable output for a relay switch, for example LEDs, Sirens, etc.
 Normally Open and Normally Closed can be selected via the Internet Explorer ActiveX control under the "I/O Setting" section on the left.
 (See pages 35, 36 for I/O settings)

PoE (Power Over Ethernet)

Power over Ethernet (PoE) is a technology that integrates power into a standard LAN infrastructure. It enables power to be provided to the network device, such as an IP phone or a network camera, using the same cable that is used for the network connection.

The PoE switch eliminates the need for power outlets at the camera locations and enables an easier application of uninterruptible power supplies (UPS) to ensure 24 hours a day, 7 days a week operation.

A 802.3af, 15.4W PoE Switch is recommended with 6521 and 6522.

If using a PoE switch that does not meet this specification, full functionality may not be supported.

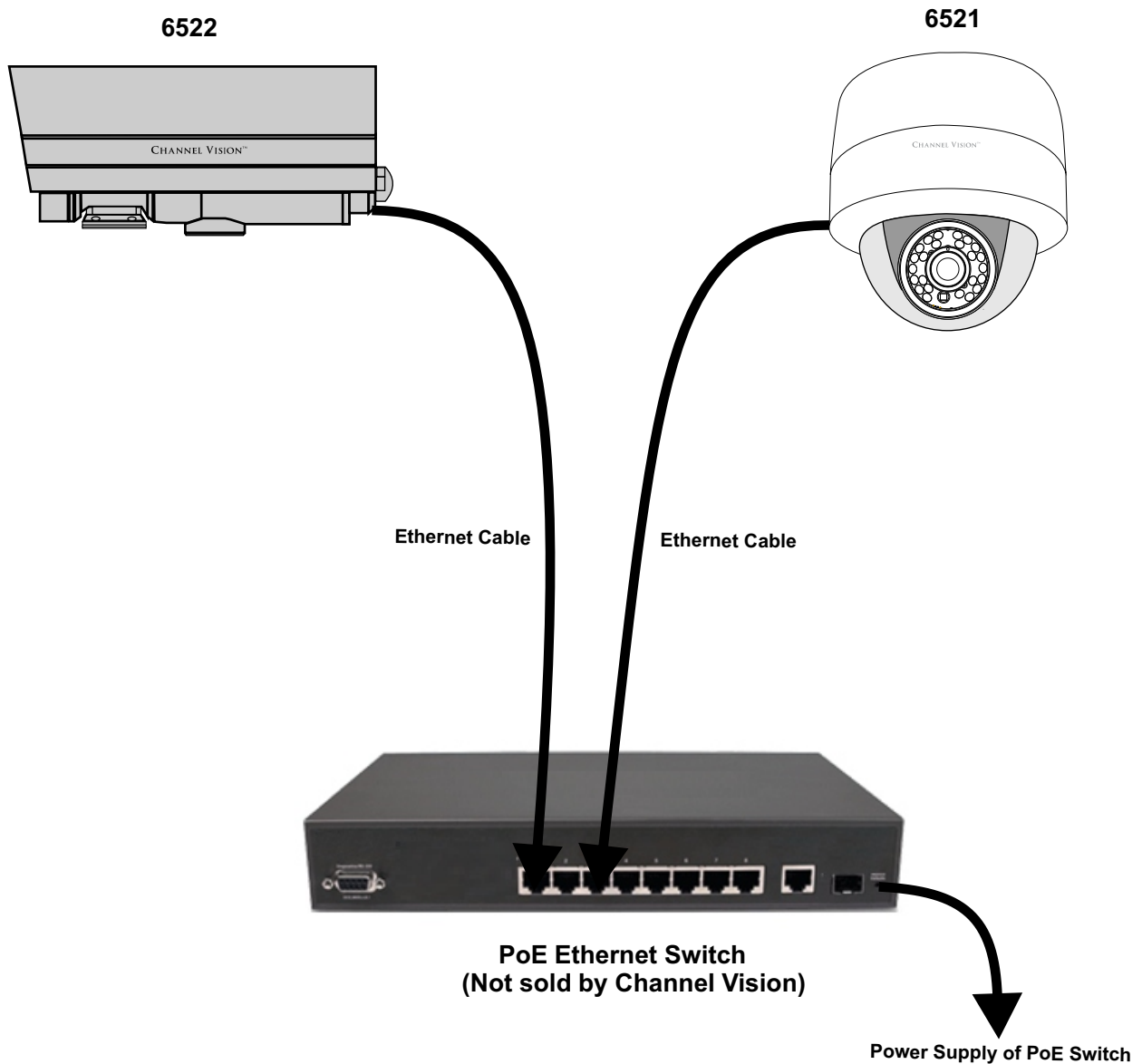

Assigning an IP Address

- 1.) Use the software, "IP Installer" to assign the IP address to your 6521 or 6522. You can find "IP Installer" in the supplied CD.
- 2.) Execute IP Installer. This is located on your disk under the folder "Megapixel Camera Network Search Application"
- 3.) If Windows prompts you to unblock IP Installer, you must select "unblock"

There are 3 kinds of IP configuration

- A.) Fixed IP (Public IP or Virtual IP)
- B.) DHCP (Dynamic IP)
- C.) Dial-up (PPPoE)

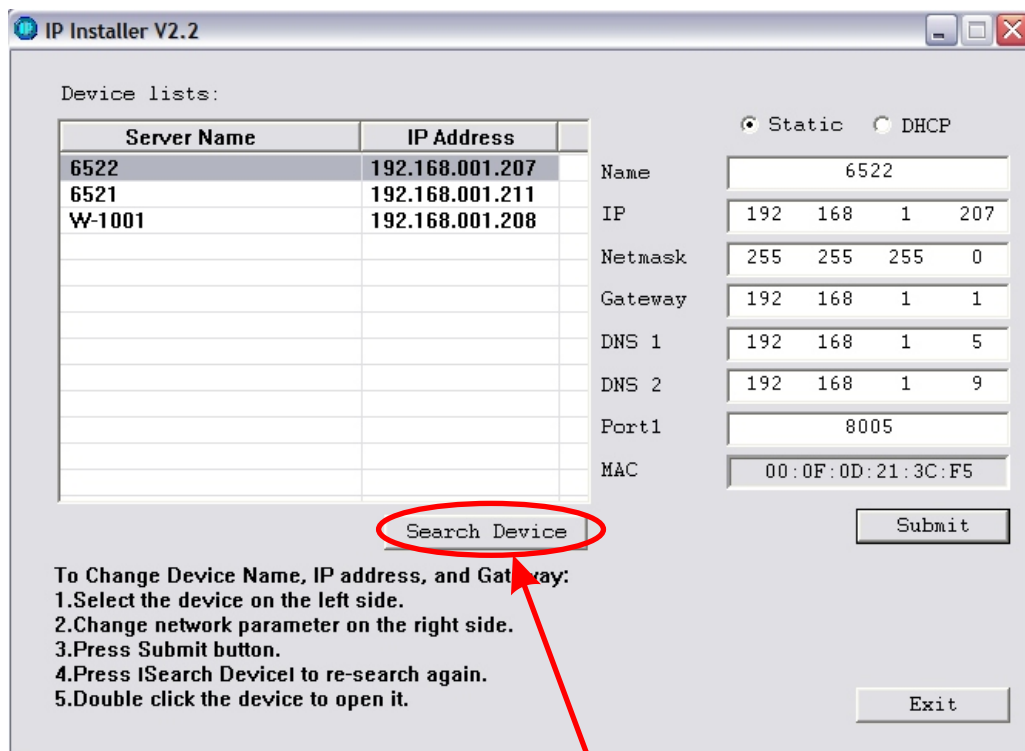

"IP Installer" will search all IP Cameras connected to your LAN network. The user can click "Search Device" to search again.

Assigning an IP Address /cont

1.) Click the start icon on your computer



2.) Click the 'Run' icon on your computer.

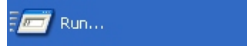

3.) Type in 'cmd' and press enter on your keyboard, or press ok.

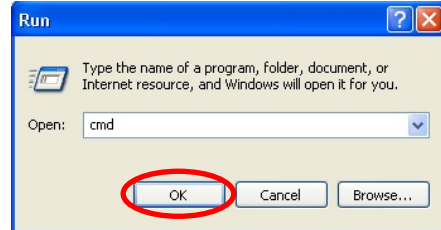

4.) Type in 'ipconfig /all' into the DOS prompt that appears. Press enter.

5.) Write down your computer's IP address.

It is important that we do not use the same IP address for our IP Camera.

In the example below, the computer's IP address is 192.168.1.74.

The IP address of the IP Camera must be different than the IP address in the computer.

Each networkable device in your network has an IP address assigned. You need to be sure the IP you choose for your IP camera is not the same as any other device on your network.

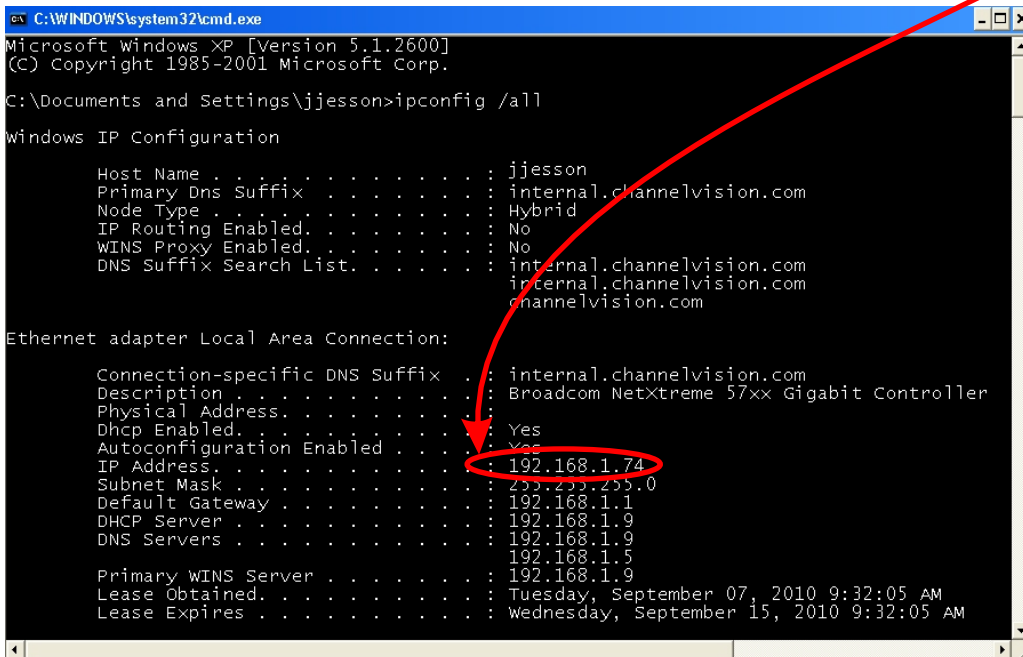

Assigning an IP Address /cont

6.) Copy/write down the following information from the DOS prompt.

- A.) Default Gateway (Example 192.168.1.1)
- B.) DNS Server (if 2 servers, use the first one, for example 192.168.1.9)
- C.) Subnet Mask (Example 255.255.255.0)

```
C:\WINDOWS\system32\cmd.exe
Microsoft Windows XP [Version 5.1.2600]
(C) Copyright 1985-2001 Microsoft Corp.

C:\Documents and Settings\jjesson>ipconfig /all

Windows IP Configuration

    Host Name . . . . . : jjesson
    Primary Dns Suffix . . . . . : internal.channelvision.com
    Node Type . . . . . : Hybrid
    IP Routing Enabled. . . . . : No
    WINS Proxy Enabled. . . . . : No
    DNS Suffix Search List. . . . . : internal.channelvision.com
                                      internal.channelvision.com
                                      channelvision.com

Ethernet adapter Local Area Connection:

    Connection-specific DNS Suffix . . : internal.channelvision.com
    Description . . . . . : Broadcom NetXtreme 57xx Gigabit Controller
    Physical Address. . . . . :
    Dhcp Enabled . . . . . : Yes
    Autoconfiguration Enabled . . . . : Yes
    IP Address . . . . . : 192.168.1.74
    Subnet Mask . . . . . : 255.255.255.0
    Default Gateway . . . . . : 192.168.1.1
    DHCP Server . . . . . : 192.168.1.9
    DNS Servers . . . . . : 192.168.1.9
                          192.168.1.5
    Primary WINS Server . . . . . : 192.168.1.5
    Lease Obtained. . . . . : Tuesday, September 07, 2010 9:32:05 AM
    Lease Expires . . . . . : Wednesday, September 15, 2010 9:32:05 AM
```

Assigning an IP Address /cont

7.) Enter the information you wrote down from step 6 on page 9 into the IP camera network page

A.) Default Gateway (Enter this number under “Gateway”)

B.) DNS Server (Enter this number under “DNS 1”)

C.) Subnet Mask (Enter this number under “Netmask”)

8.) Giving the IP Camera a unique IP address.

Assign an IP address to the IP Camera by using the first 3 sets of numbers of your default gateway. A IP address, has 4 sets of numbers, each followed by a period. For example, xxx.xxx.xxx.xxx My default gateway is 192.168.1.1 So, for example, my IP Camera’s address will start with 192.168.1.xxx

9.) Make sure you use a number different that your computer’s IP address.

(Generally between 2-250) This number needs to be out of the range of DHCP. DHCP is assigned with your router, and can be checked by logging into the router.

My computer’s IP address is 192.168.1.74. I have used 192.168.1.208 for my IP Camera.

You must choose a number that is different from your computer’s IP.

If your IT technician has designated a static internal IP for your IP Camera, use that address.

10.) To assign the port, choose a port between 5400-9000, and type it into “Port 1” If a specific port has been designated for your security system, that can also be used, even if the number is not within the range of 5400-9000.

The screenshot shows the IP Installer V2.2 window. On the left, a table lists devices: 'Parking Lot' with IP 192.168.001.209 and 'North West Wall' with IP 192.168.001.208. The 'North West Wall' device is selected. On the right, network configuration fields are shown: 'Static' is selected, 'Name' is 'North West Wall', 'IP' is '192.168.1.208', 'Netmask' is '255.255.255.0', 'Gateway' is '192.168.1.1', 'DNS 1' is '192.168.1.5', 'DNS 2' is '192.168.1.9', 'Port1' is '8006', and 'MAC' is '00:0F:0D:20:F0:1B'. Red arrows and circles point to these fields with explanatory text.

Annotations:

- First 3 numbers are same as computer (pointing to 192.168.1 in IP)
- Select “Static” (pointing to the Static radio button)
- Name (pointing to North West Wall)
- Fourth number (different than computer) (pointing to 208 in IP)
- Subnet Mask (same as computer) (pointing to 255.255.255.0)
- Default Gateway (same as computer) (pointing to 192.168.1.1)
- DNS Server 1 (same as computer) (pointing to 192.168.1.5)
- DNS Server 2 (same as computer) (pointing to 192.168.1.9)
- Port (A port between 8000-8999 is recommended, but any network port can be used) (pointing to 8006)

Buttons: Search Device, Submit, Exit

Instructions:

To Change Device Name, IP address, and Gateway:
1. Select the device on the left side.
2. Change network parameter on the right side.
3. Press Submit button.
4. Press [Search Device] to re-search again.
5. Double click the device to open it.

To change numbers, select the appropriate area on IP installer with your mouse, and type in the info.

*Disclaimer: This is an example based on a general network setup. All networks do not match these settings exactly, as all networks are different

Connecting To Your Camera

1.) Open Internet Explorer. Type the IP address of the IP camera into the browser link window. Also, make sure to type the port at the end of the link.

For example, I will type in **http://192.168.1.207:8005**

2.) You will be prompted for a username and password.

The default username is 'admin'

The default password is 'admin'

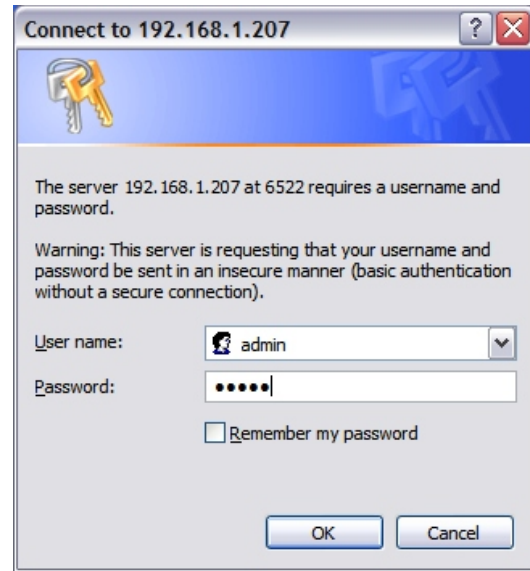

Installing The ActiveX Control

1.) The first time you connect to the camera via Internet Explorer, it will ask you to install the ActiveX control. Internet Explorer 6, 7, 8, or 9 must be used to run this ActiveX control.

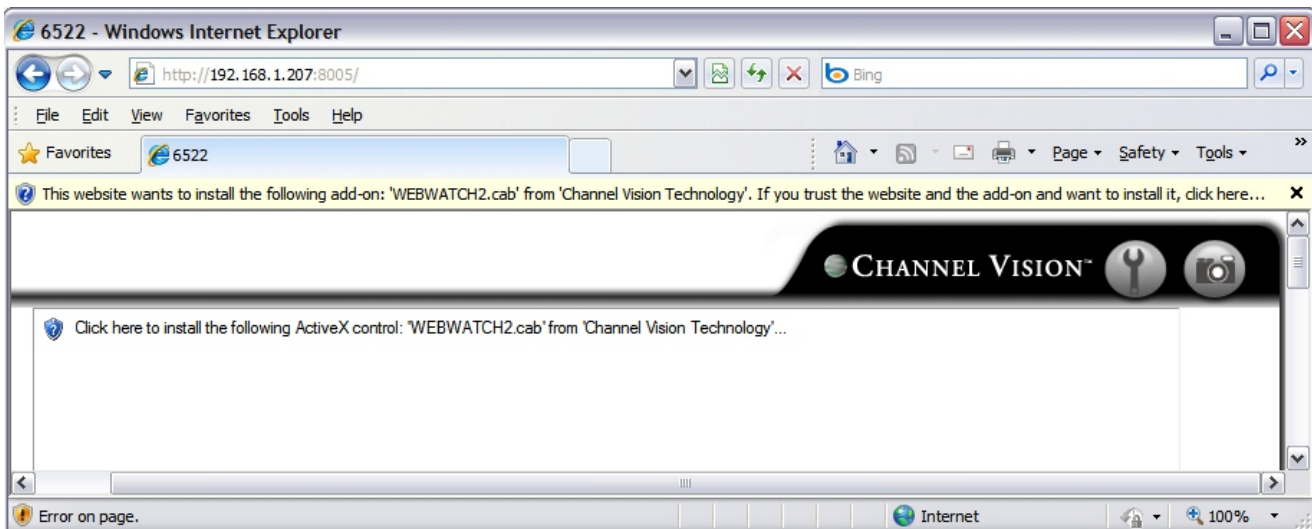

Configuring Internet Explorer

If the installation of the ActiveX control fails, for example the browser page says “done” but you do not see your camera, please check the security settings for your IE browser. Follow the instructions below.

Step 1

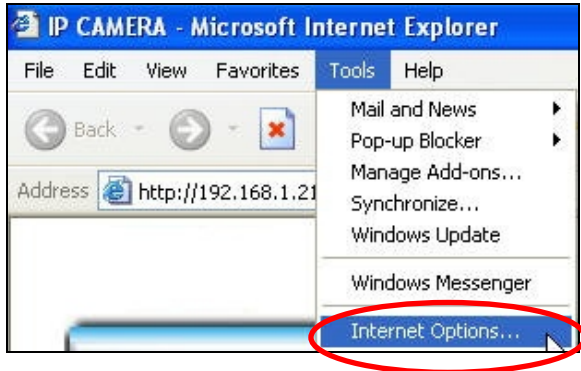

Step 2

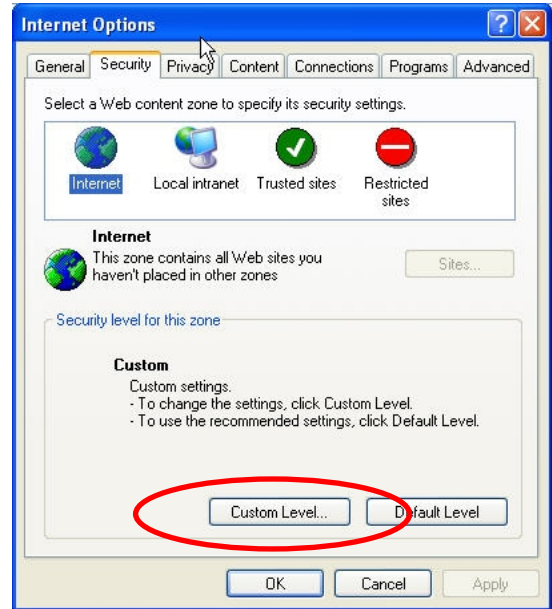

Step 3

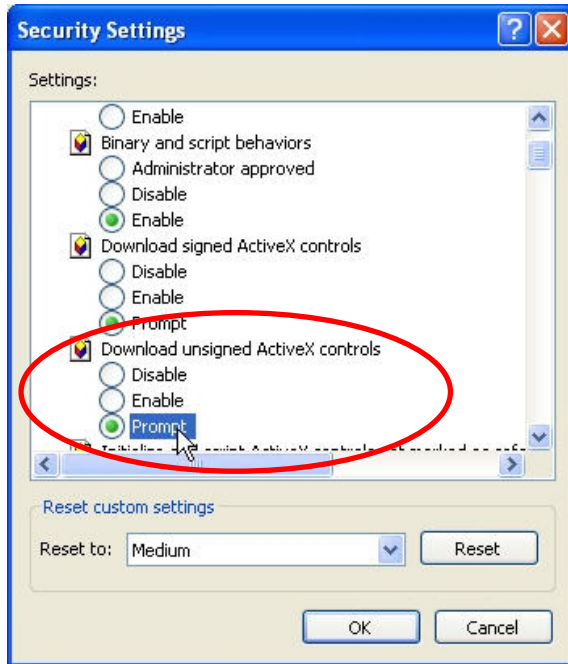

Step 4

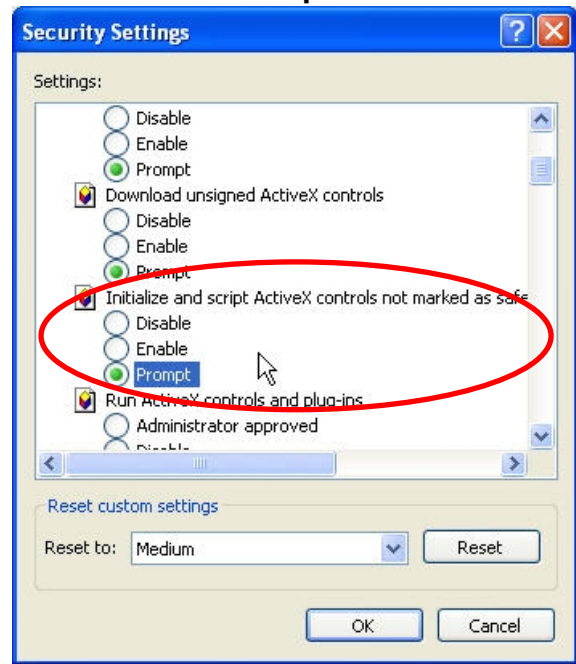

When popup the following dialogue box, click “Yes”.

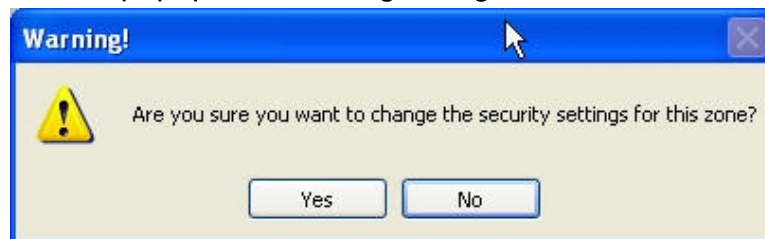

Step 5

Live Viewing

Once you connect to your camera, you will see the following screen. Below the icons and their functionality is described.

The screenshot shows a live video feed of a parking lot with a white pickup truck and a silver sedan. The interface includes a top bar with 'CHANNEL VISION' and two icons: a wrench (Settings) and a camera (Snapshot). Below the video feed is a control bar with the following elements:

- Metadata: 2010/DEC/17 02:53:41 Size:1600x1200 FPS: 15
- Stream Selection: default (dropdown), Streaming 1 (dropdown)
- Chatting:
- Online Visitor: 1
- Relay Out: ON OFF

Annotations with red arrows point to these elements:

- Snapshot**: Points to the camera icon.
- Settings**: Points to the wrench icon.
- Streaming 1**: Controls the selection of the video stream that is being viewed.
- Chatting**: Activates 2-way audio.
- Online Visitor: 1**: Shows the number of users connected at any given time.
- Relay Out**: Activates relay output.
- default**: Controls the physical size of the streaming video on the browser screen.

Format: Year/Month/Day/Hour/Minute/Second/ Image Size/Frames Per Second

Live Viewing/cont.

1.) This icon opens the settings' menu 

2.) This icon takes a snapshot 

3.) This icon show system time, video resolution, and video refreshing rate

2010/NOV/25 02:39:04 Size:800x592 FPS: 10

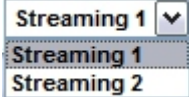
4.) The bottom bar has an icon that allows you to select which stream you want to view. Stream 1 is usually the larger, better quality stream. Stream 2 is the smaller stream, generally used for mobile viewing 





5.) These cameras support 2 way audio.
The bottom bar has an icon will activate 2 way audio  Chatting:
For 2 way audio to function, you need a microphone plugged into the computer.

6.) The bottom bar has an icon shows how many users are connected  Online Visitor : 1
to the IP camera.

7.) This icon will control/activate the relay output on the camera wire pigtail. A relay can activate lights, alarms, or anything that uses a contact closure.  Relay Out: ON OFF

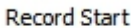
8.) If you double click the video feed, it will make the video full screen.
To change video back to normal mode, press 'Escape' on your keyboard, or double click anywhere in the video feed a second time.

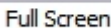
9.) If you right click on the video, you have access to several different functions.

- A.) Snapshot: Takes a snapshot 
- B.) Record Start : Records video to your computer 
- C.) Mute: Mutes 2 way audio, if activated 
- D.) Full Screen: Makes the IP camera full screen 
- E.) Zoom: Digital zoom. This is explained below 

Digital zoom

- 1.) Select "Enable digital zoom"
- 2.) Select the area of the screen you wish to zoom in on
- 3.) Select the zoom level

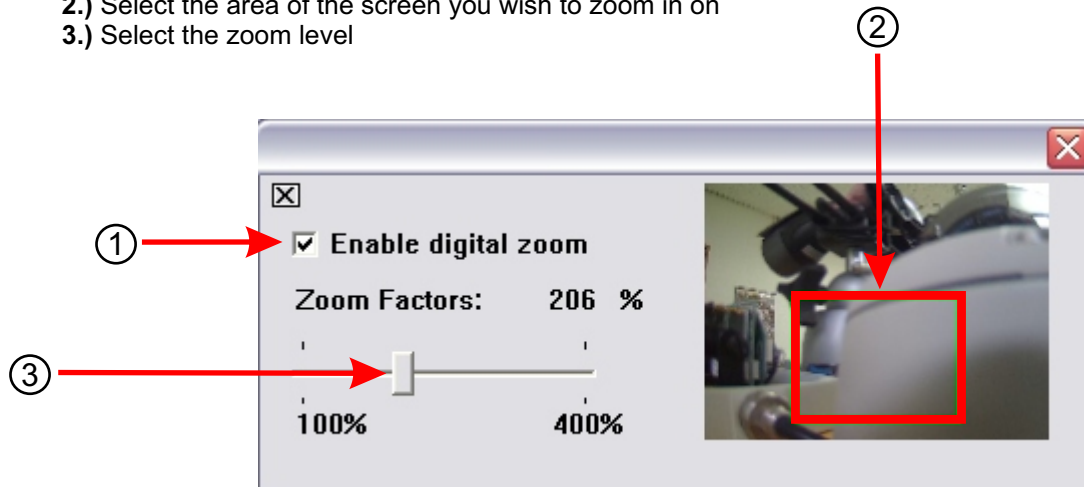

Configuration

1.) Select this icon to enter the settings menu



①



2.) Select this icon to go back to your live video feed



②

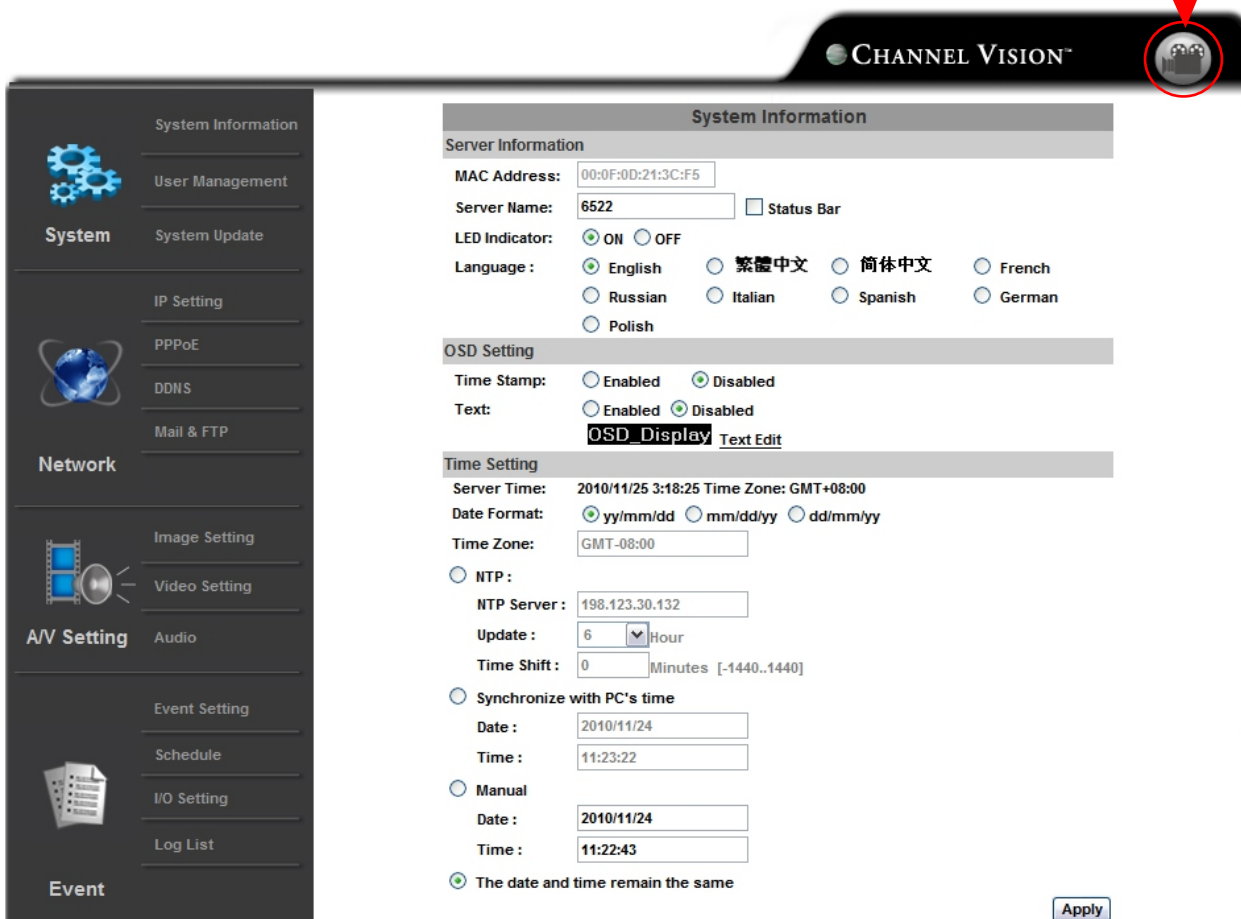

System Configuration

System Information:

Use the number scheme below for a description of each item:

- 1.) **MAC Address:** (Media Access Control) address; This is a unique identifier assigned to IP devices for communication with the network. Your IP camera is pre-set with a MAC address
- 2.) **Server name:** Select to edit the camera name
- 3.) **LED Indicator:** Select On/Off to toggle the blinking LED light in the camera
- 4.) **Language:** Select a language to change the language of the ActiveX interface
- 5.) **Status Bar:** Select On/Off to toggle the information bar (below the main video stream)
- 6.) **Time Stamp:** Select Enabled/Disabled to turn the video timestamp on or off
- 7.) **Text:** Select Enabled/Disabled to specify the name that can be displayed on the top left area of the screen
- 8.) **Server Time:** This shows the current time on your IP camera
- 9.) **Date Format:** Select to choose your desired date format
- 10.) **Time Zone:** This shows your current time zone
- 11.) **NTP:** The Network Time Protocol is a protocol for synchronizing the clocks of computer systems
- 12.) **NTP Server:** If you have a NTP server, input it here
- 13.) **Update:** If using an NTP server, select this drop down menu to choose the update interval
- 14.) **Time Shift:** Time shift is used to compensate for the time it takes to server to process the sync request for your time. This is usually not needed.
- 15.) **Synchronize with PC's time:** Select this to match your computer's clock to your IP camera
- 16.) **Apply:** Select this button to save your changes

The screenshot shows the 'System Information' configuration page. It is divided into several sections: 'Server Information', 'OSD Setting', 'Time Setting', and 'Manual'. Each setting is accompanied by a numbered callout (1-16) in a red circle. The 'Server Information' section includes fields for MAC Address (00:0F:0D:21:3C:F5), Server Name (6522), LED Indicator (ON), and Language (English). The 'OSD Setting' section includes Time Stamp (Disabled) and Text (Disabled). The 'Time Setting' section includes Server Time (2010/11/25 3:28:44), Date Format (yy/mm/dd), Time Zone (GMT-08:00), NTP (unchecked), NTP Server (198.123.30.132), Update (6 Hour), Time Shift (0 Minutes), and Synchronize with PC's time (unchecked). The 'Manual' section includes Date and Time fields for manual synchronization. The 'Apply' button is located at the bottom right.

System Information

Server Information

① **MAC Address:** 00:0F:0D:21:3C:F5

② **Server Name:** 6522 **Status Bar** ⑤

③ **LED Indicator:** ON OFF

④ **Language :** English 繁體中文 简体中文 French
 Russian Italian Spanish German
 Polish

OSD Setting

⑥ **Time Stamp:** Enabled Disabled

⑦ **Text:** Enabled Disabled

OSD_Display Text Edit

Time Setting

⑧ **Server Time:** 2010/11/25 3:28:44 Time Zone: GMT+08:00

⑨ **Date Format:** yy/mm/dd mm/dd/yy dd/mm/yy

⑩ **Time Zone:** GMT-08:00

⑪ **NTP :**

⑫ **NTP Server :** 198.123.30.132

⑬ **Update :** 6 Hour

⑭ **Time Shift :** 0 Minutes [-1440..1440]

⑮ **Synchronize with PC's time**

Date : 2010/11/24

Time : 11:33:41

Manual

Date : 2010/11/24

Time : 11:22:43

The date and time remain the same

⑯ **Apply**

User Management

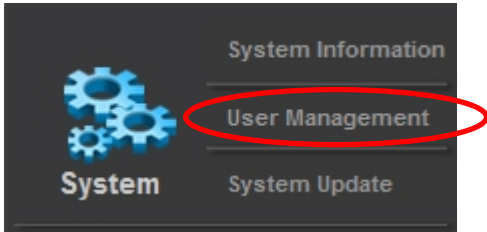

User management:

This IP camera supports 3 different types of users.

- 1.) Administrator
- 2.) General
- 3.) Anonymous

A screenshot of a web interface titled 'User Management'. It has three main sections: 'Anonymous User Login' with radio buttons for 'YES' and 'NO' (both circled in red) and a 'Setting' button; 'Add User' with input fields for 'Username:', 'Password:', and 'Confirm:'; and 'User List' with a table. The table has columns for 'Username', 'User Group', 'Modify', and 'Remove'. The first row shows 'admin' as the username and 'Administrator' as the user group. The 'Modify' column contains an 'Edit' button (circled in red), and the 'Remove' column contains an 'Add/Set' button (circled in red). Red arrows point from the 'Edit' and 'Add/Set' buttons to the text instructions below.

Click "Yes" to allow anonymous user access

Click "Add/Set" to add a user

Click "Edit" to modify a user.

When you click edit, the following window will pop up:

(Shown below.)

A screenshot of a 'User Setup' dialog box in a Windows Internet Explorer browser window. The browser title is 'User_Setting - Windows Internet Explorer' and the address bar shows 'http://192.168.1.207:8005/muser.html'. The dialog box has three input fields: 'Username:' with 'admin' entered, 'Password:', and 'Confirm:'. An 'OK' button is circled in red. A red arrow points from the 'OK' button to the text instructions below.

Add the username and password, and click "OK" to save your new user.

System Update

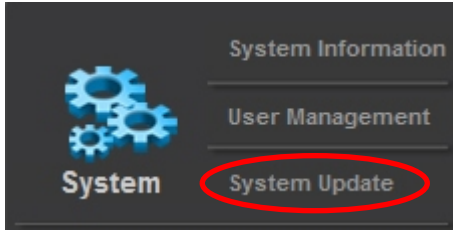

System Update: This menu is used to perform the following functions:

- 1.) Firmware Update:** Channel Vision will update the firmware from time to time. By registering your IP camera, you have access to all firmware improvements and extended warranty options. How? See our warranty page for more information. Below is a link to the warranty page.

Http://www.channelvision.com/index.php/Table/PRODUCT-WARRANTY/

To load new firmware, press "Browse" and select the firmware.bin file.

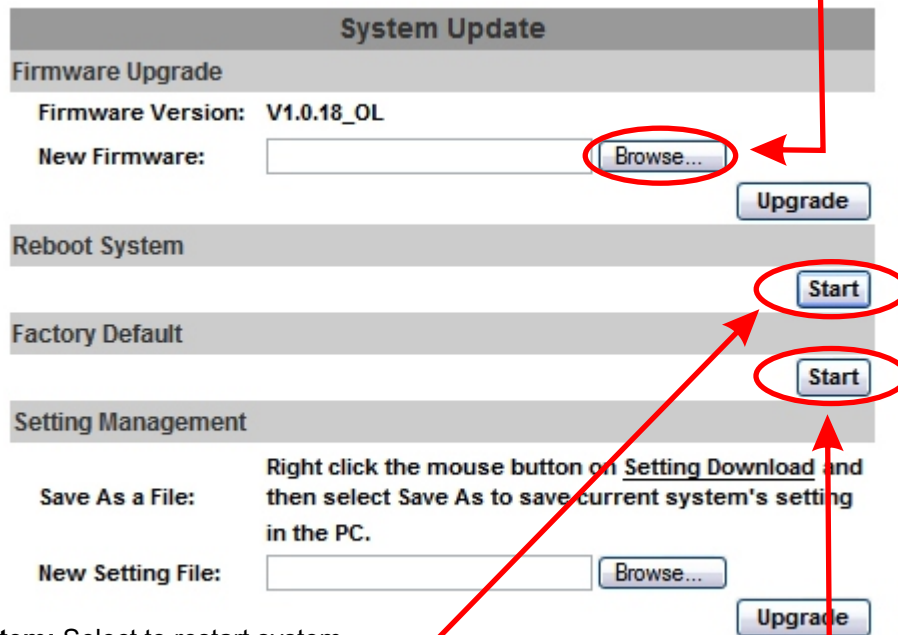

- 2.) Restart System:** Select to restart system. You can reset the IP camera to factory default settings if desired. If you backup your settings, you can load your backup file where it says "New Setting File"

3.) Settings backup:

You can backup your settings by right clicking your mouse on "Setting Download" and selecting "Save Target As". You may also load previously saved settings files this way. When loading previously saved files, click "Browse" and then "Upgrade"

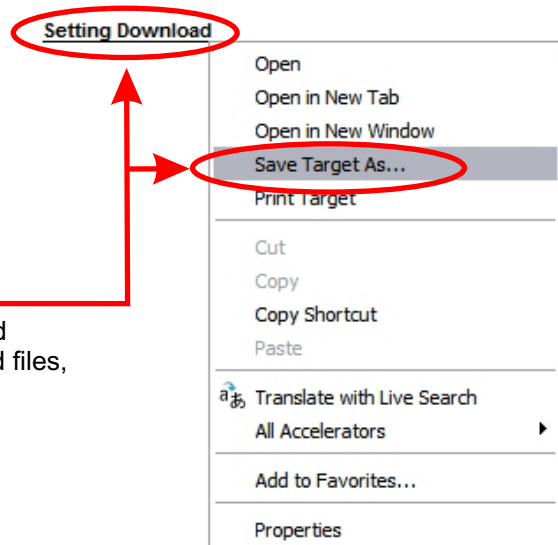

Network

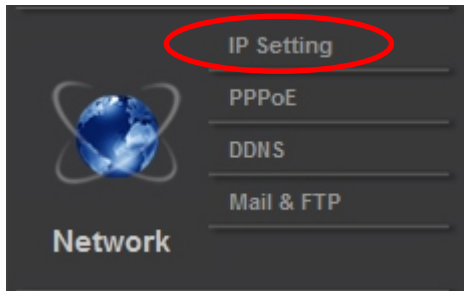

Network Setup/IP Setting: This setting is for the external viewing of camera over the internet. Once set up, you will be able to view this camera from anywhere in the world.

This IP camera supports DHCP and Static settings.

If you are new to installing an IP camera, use #2 (**Static IP**)

- 1.) **DHCP:** If you use this setting, your IP information will be pulled automatically from your router. This not recommended if you are going to view this camera outside of the building that it resides in.
- 2.) **Static IP:** This is an IP that you manually set. This IP must not be the same as any other device within your network. You must also set default gateway, DNS server, subnet mask, and DNS server. Please refer to page 6 & 7 for instructions on how to obtain these numbers.
- 3.) **Port Assignment:** You can assign different ports for your camera. (Explained below.)
 - A.) **Web Page Port:** (This is the port that 99% of installations will use)
A web page port is used to transmit data out of your network. For example, If my external IP address is **http://67.88.12.50**, and my port was 5400, I would put a ":" and the port. The final address would be **http://67.88.12.50:5400**
For information on network ports, please refer to the link below:
http://en.wikipedia.org/wiki/Network_ports
 - B.) **RTSP Transmitting Port:** For information on RTSP, please refer to the link below.:
http://en.wikipedia.org/wiki/Real_Time_Streaming_Protocol
 - C.) **RTP start and end port:**
In RTSP mode, you may use TCP and UDP for connecting
TCP connection uses RTSP port (554) UDP connection uses RTP start & end port.
- 4.) **UPnP:** This IP camera supports UPnP. If this service is enabled on your computer, the camera will be automatically detected and a new icon will be added to "My Network Places". For information on UPnP, please refer to the link below:
<http://en.wikipedia.org/wiki/UPNP>

Below are instructions on how to activate UPnP on your computer:

- A.) Open the control panel from the start menu.
- B.) Select "Add/Remove programs"
- C.) Select "Add/Remove Windows components"
- D.) Open "Networking Services" section
- E.) Click "Details" and select UPnP to setup the service.
- F.) Once activated, the IP camera icon will appear in "My Network Places"
- G.) You can now double click that icon to access the camera with your IE browser.

Network/cont

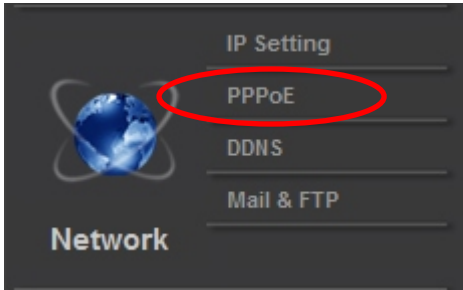

Network/cont: Below is an example of the network settings menu. This is where you key in all of your IP information from your network. These settings must be entered correctly in order for the IP camera to be viewable over the network.

A screenshot of the "IP Setting" configuration page. It is divided into several sections: "IP Assignment" with radio buttons for "DHCP" and "Static" (selected); "IP Address:" (192.168.1.207), "Subnet Mask:" (255.255.255.0), "Gateway:" (192.168.1.1), "DNS 0:" (192.168.1.5), and "DNS 1:" (192.168.1.9); "Port Assignment" with "Web Page Port:" (8005), "RTSP Port:" (554), "RTP Start Port:" (5000) [1024..10000], and "RTP End port:" (9000) [1025..10000]; and "UPnP" with "UPnP:" (Enabled), "UPnP Port Forwarding:" (Disabled), "External Web Port:" (80), and "External RTSP Port:" (554). An "Apply" button is at the bottom right.

5.) **PPPoE:** Check the PPPoE “Enabled” button to activate this function.

A screenshot of the "PPPoE" configuration page. It has a "PPPoE Setting" section with radio buttons for "Enabled" (circled in red) and "Disabled" (with a red arrow pointing to it). Below are "Username:" and "Password:" input fields. A "Send mail after dialed" section has a checkbox for "Enabled" (unchecked) and a "Subject:" field with "PPPoE From IPcam". An "Apply" button is at the bottom right.

You can key in a username and password for the connection if you are using ADSL. Send mail after dialed: When connected to the internet, this IP camera will send a email to the specified email account. To configure the IP camera email settings, please refer to the “Mail and FTP Settings”

Network/cont



Network/cont: DDNS:

This IP camera supports DDNS (Dynamic DNS) service. Select "Enabled" to enable the DDNS service.

For viewing the cameras over the internet while using a dynamic (rotating) IP address, there are many services available online. For more details, please review the "instruction manual" tab on the product info page located at www.channelvision.com and click on the "DDNS basic instructions" PDF file.

A screenshot of the DDNS configuration page. The page title is 'DDNS'. Under 'DDNS Setting', there are two radio buttons: 'Enabled' (circled in red) and 'Disabled'. Below this are fields for 'Provider:' (a dropdown menu showing 'dyndns.org'), 'Hostname:', 'Username:', and 'Password:' (all three circled in red). There is also a 'Schedule Update:' field with '1440' and 'Minutes' (circled in red). Below these fields is a 'State' section with a dropdown menu showing 'Idle'. At the bottom right of the configuration area is an 'Apply' button (circled in red). Red arrows point from the 'Apply' button to the 'Enabled' radio button, and from the 'Apply' button to the 'Hostname:', 'Username:', and 'Password:' fields. Another red arrow points from the 'Apply' button to the 'Schedule Update:' field.

Note:

1. Schedule Update: Feature of DDNS schedule update is designed for IP products which installed behind the ICS or NAT devices. Update range from every 5 (minutes) to 5000 (minutes) and 0 remain to off.
2. Please note that the hostname will be blocked by DynDNS.org if schedule update is more than once every 5 minutes to 60 minutes. In general, schedule update in every 1440 minutes is recommended.

- 1.) Enable the service
- 2.) Key in the DynDNS server name, username, and password
- 3.) Set up the IP update refresh rate
- 4.) Click "Apply"
- 5.) If it updates to often, the IP will be blocked by DynDNS
Channel Vision recommends you set it to update once per day (1,440 minutes)

Network/cont

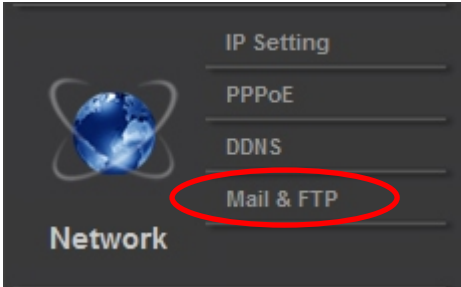

Mail & FTP: Enter your Mail and FTP information into the menu below:

Mail: Mail is a way the IP camera can send you an email when certain actions occur, for example motion, a contact closure on the sensor, etc. For more details, please see page 32

FTP: FTP is for uploading recorded files to a designated FTP site

Mail & FTP	
Mail Setting	
Login Method:	Account <input type="button" value="v"/>
Mail Server:	<input type="text"/>
Username:	<input type="text"/>
Password:	<input type="text"/>
Sender's Mail:	<input type="text"/>
Receiver's Mail:	<input type="text"/>
Bcc Mail:	<input type="text"/>
Mail Port:	25 (Default 25)
<input type="button" value="Test"/>	
FTP Setting	
FTP Server:	<input type="text"/>
Username:	<input type="text"/>
Password:	<input type="text"/>
Port:	21
Path:	/
Mode:	PORT <input type="button" value="v"/>
Create the folder:	Yes <input type="button" value="v"/> (ex:Path/20100115/121032m.avi)
<input type="button" value="Test"/> <input type="button" value="Apply"/>	

Please note: standard servers block devices such like this, due to spam settings. You may not be able to use the following free services:

- Live.com
- Hotmail.com
- Yahoo.com
- Gmail.com
- Mail.com
- Apple.com
- MSN.com

Video Settings

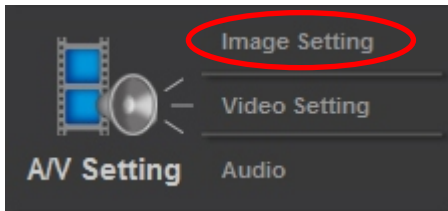

Image Setting: You can adjust the following items on this camera:

- 1.) **Brightness:** This adjusts the brightness level of the camera
- 2.) **Contrast:** This adjusts the difference in color and light between parts of an image
- 3.) **Sharpness:** This adjusts how sharp the image appears
- 4.) **AGC:** This adjusts the automatic gain control
- 5.) **BLC:** This turns off or on the back light compensation for the video
- 6.) **AWB R-Gain:** This adjusts the auto white balance right
- 7.) **AWB B-Gain:** This adjusts the auto white balance left
- 8.) **Night Mode:** This adjusts the frame rate during low light recording or viewing
- 9.) **Video Orientation:** This will allow you to flip or mirror the video stream

Camera

Privacy Mask

Area 1 Area 2 Area 3 Save

Image Setting

①	Brightness:	0	▼
②	Contrast:	0	▼
③	Sharpness:	0	▼
④	AGC:	8x	▼
⑤	BLC:	<input type="radio"/> ON <input checked="" type="radio"/> OFF	
⑥	AWB R-Gain:	0	▼
⑦	AWB B-Gain:	0	▼
⑧	Night Mode:	Max 5 frame rate	▼
⑨	Video Orientation:	<input type="checkbox"/> Flip <input type="checkbox"/> Mirror	

Default

You can reset your IP camera's image settings to default by pressing the "default" button

Video Settings/cont.

The 6521 and 6522 IP cameras are varifocal.
This means you can adjust the zoom and focus level of the camera from **2.7-9mm** on the 6521 and **3.6-16mm** on the 6522

How to adjust zoom and focus on the 6522



- 1.) Using a flat head screwdriver, adjust the zoom or focus screws on the 6522 camera
To adjust the zoom and focus, the Channel Vision 15-AU25MM portable test monitor is recommended



Video Settings/cont.

To adjust zoom and focus on the 6521, first, you have to take off the plastic dome piece. To do this, unscrew the 5 vandal resistant screws using the tool that comes with the 6521.



How to adjust zoom and focus on the 6521

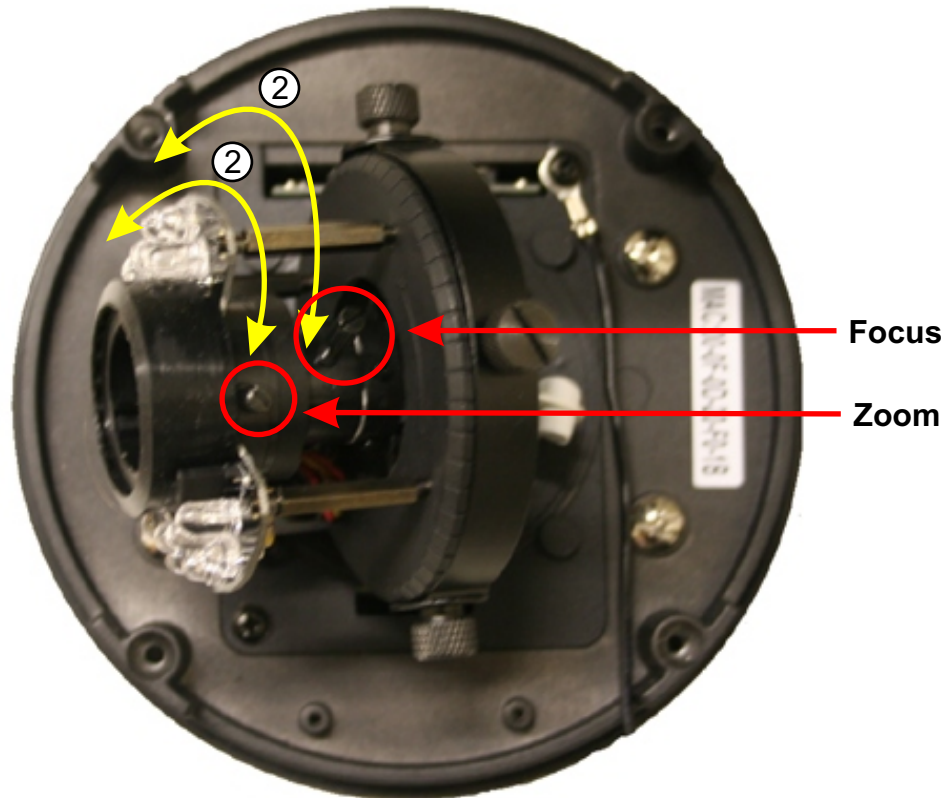

- 1.) You will need to unscrew each of the knobs slightly (counter-clockwise) with your fingers or a flat head screwdriver. If you do not unscrew the knobs first, you will be unable to move them
- 2.) Once you have loosened the zoom or focus knob, use the knob as a lever to turn the circular lens piece
- 3.) Once you are done adjusting your zoom and focus, screw the knobs back in (clockwise)

Video Settings/cont.

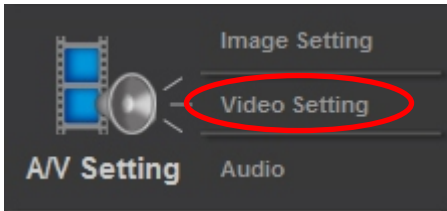

Video Setting:

Click the drop down list to select Input Resolution, Video System and TV Output

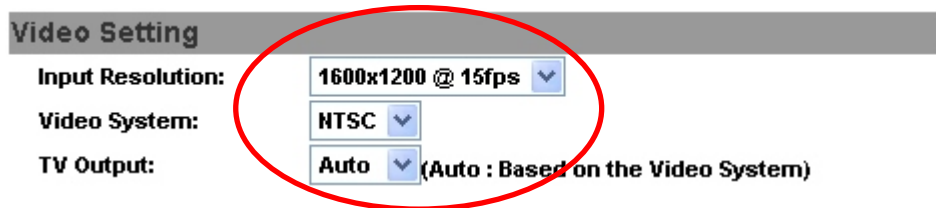

Streaming: Basic mode:

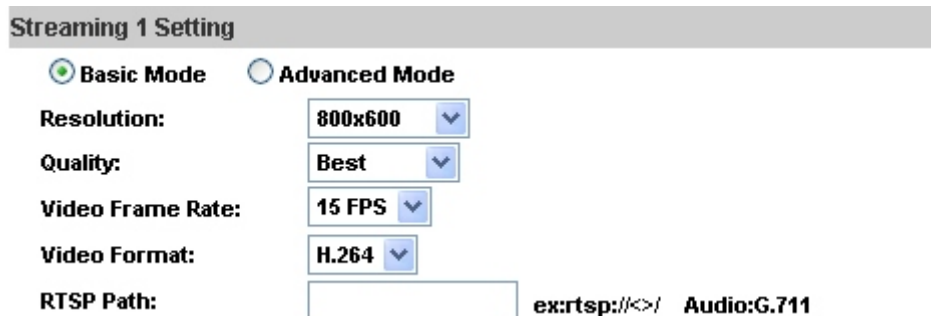

1.) Resolution:

There are 8 resolutions you can choose from.

1600x 1200, 1280x1024, 1280x960, 1280x720, 800x600, 640x480, 320x240, & 176x144

2.) Quality:

There are 5 levels you can adjust to:

Best, High, Standard, Medium, & Low.

If you use the highest settings, the network streaming speed will be slower

Also, if you record any files, the higher the quality, the larger the file will be

3.) Video Frame Rate: The video refresh rate per second

Setting max is 30 FPS (NTSC) and 25 FPS (Pal) at 1280x720 and best quality

4.) Video Format: This describes the codec use for compression. H.264 is newer and higher quality, and MJPEG (JPEG) is an older, but may stream faster

5.) RTSP Path: RTSP output name.

For example, if I choose camera, the rtsp path would be as follows: **rtsp://camera/**
(For more information on RTSP, follow the link on page 19)

Video Settings/cont.

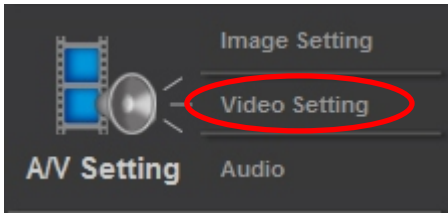

Streaming (Advanced Mode):

Streaming 1 Setting

Basic Mode **Advanced Mode**

Resolution: 800x600

Bitrate Control Mode: CBR VBR

Video Quantitative: 9

Video Bitrate: 1.5Mbps

Video Frame Rate: 15 FPS

GOP Size: 1 X FPS **GOP = 15**

Video Format: H.264

RTSP Path: **ex:rtsp://</>/ Audio:G.711**

1.) Resolution:

There are 8 resolutions you can choose from.

1600x 1200	(UXGA)
1280x1024	(SXGA)
1280x960	(SXGA-)
1280x720	(WXGA)
800x600, 640x480	(VGA)
320x240	(qVGA)
176x144	(qCIF)

2.) Bitrate Control mode:

There are 2 choices. CBR (Constant Bit Rate) and VBR (Variable Bit Rate)

A.) CBR: 32Kbps-4Mbps (The higher the CBR, the better your video quality will be)

B.) VBR: 1 (Low) -10 (High) Compression rate. The higher the compression rate the higher the picture quality, and vice versa. The balance between VBR and network bandwidth will affect your picture quality. When using VBR, it is less likely that your streaming video will break up or lag.

3.) Video Frame Rate: The video refreshing rate per second

NTSC: Max 30 frames per second PAL: Max 25 Frames per second

4.) GOP Size: This means 'Group of Pictures.' The higher the GOP is, the better the quality of the images

5.) Video Format: This describes the codec use for compression. H.264 is newer and higher quality, and MJPEG (JPEG) is older, but will stream faster

6.) RTSP Path: RTSP output connecting route

For example, **rtsp://camera/**

(For more information on RTSP, follow the link on page 19)

Video Settings/cont.

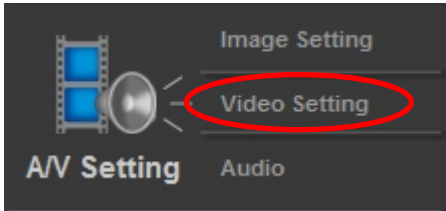

Stream 2 (Basic Mode):

Streaming 2 Setting

Basic Mode Advanced Mode

Resolution: 640x480 ▼

Quality: Standard ▼

Video Frame Rate: 15 FPS ▼

Video Format: JPEG ▼

RTSP Path: v2 **ex:rtsp://<>/v2 Audio:G.711**

1.) Resolution:

There are 8 resolutions you can choose from.

1600x 1200	(UXGA)
1280x1024	(SXGA)
1280x960	(SXGA-)
1280x720	(WXGA)
800x600, 640x480	(VGA)
320x240	(qVGA)
176x144	(qCIF)

2.) Quality:

There are 5 levels you can adjust to:

Best, High, Standard, Medium, & Low

If you use the highest settings, the network streaming speed will be slower

Also, if you record any files, the higher the quality, the larger the file will be

3. Video Frame Rate: The video refreshing rate per second

4.) Video Format: This describes the codec use for compression. H.264 is newer and higher quality, and MJPEG (JPEG) is older, but may stream faster

5.) RTSP Path: RTSP output connecting route

For example, **rtsp://camera/**

(For more information on RTSP, follow the link on page 19)

Video Settings/cont

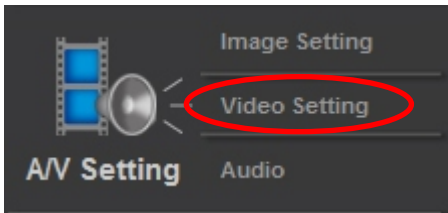

Stream 2 Advanced Mode:

Streaming 2 Setting

Basic Mode **Advanced Mode**

Resolution: 640x480

Bitrate Control Mode: CBR VBR

Video Quantitative: 7

Video Bitrate: 1.5Mbps

Video Frame Rate: 15 FPS

GOP Size: 1 X FPS

Video Format: H.264

RTSP Path: v2 **ex:rtsp://</>v2 Audio:G.711**

1.) Resolution:

There are 8 resolutions you can choose from.
1600x 1200, 1280x1024, 1280x960, 1280x720, 800x600, 640x480, 320x240,
& 176x144

2.) Bitrate Control mode:

There are 2 choices. CBR (Constant Bit Rate) and VBR (Variable Bit Rate)

3.) Video Frame Rate: The video refreshing rate per second.

4.) GOP Size: This means 'Group of Pictures.' The higher the GOP is, the better the quality of the images.

5.) Video Format: This describes the codec use for compression. H.264 is newer and higher quality, and MJPEG (JPEG) is older, but may stream faster.

6.) RTSP Path: RTSP output connecting route.

(For more information on RTSP, follow the link on page 19)

3GPP Streaming Setting

Enabled **Disabled (Resolution=176x144, FPS=5, Format=MPEG4)**

3GPP Path: 3g **ex:rtsp://</>3g Audio:AMR**

ex:rtsp://</>3gx No Audio

3GPP Streaming Mode:

- 1.) Enable or Disable 3GPP Streaming
- 2.) 3GPP: 3GPP output name

Apply

*Channel Vision recommends you use 176x144 resolution, 5FPS, MPEG4 format for 3GPP mode

Recommended Video Settings

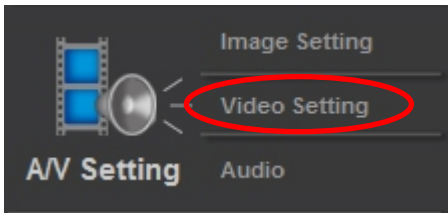

Below are a few examples of recommended settings, depending on the situation.

1.) Viewing a stationary object, or area that does not receive much movement

If the camera is looking at a stationary object, or an area that does not receive a lot of traffic or movement, the camera can be set to the highest settings. An example of the highest settings are below:

Streaming 1 Setting

Basic Mode Advanced Mode

Resolution: 1600x1200 ▾

Bitrate Control Mode: CBR VBR

Video Quantitative: 10(High) ▾

Video Bitrate: 2Mbps ▾

Video Frame Rate: 15 FPS ▾

GOP Size: 2 X FPS ▾ GOP = 30

Video Format: H.264 ▾

2.) Viewing an area that receives a lot of traffic or movement

If the camera is looking at an area that views constant or near constant movement, a medium setting is recommended. An example of medium settings are below:

Streaming 1 Setting

Basic Mode Advanced Mode

Resolution: 1280x720 ▾

Bitrate Control Mode: CBR VBR

Video Quantitative: 5 ▾

Video Bitrate: 2Mbps ▾

Video Frame Rate: 10 FPS ▾

GOP Size: 1/2 X FPS ▾ GOP = 5

Video Format: H.264 ▾

Recommended Video Settings/cont

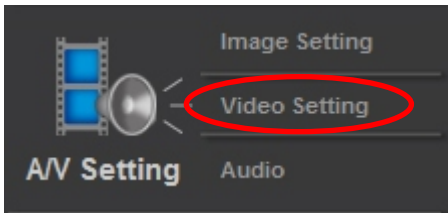

3.) Viewing a 6521 or 6522 on a slow internet connection

If the 6521 or 6522 is installed on a network that does not have a very fast internet connection, or you are viewing on a network with limited bandwidth, the example below is recommended.

Streaming 1 Setting

Basic Mode Advanced Mode

Resolution: 640x480 ▾
Quality: Standard ▾
Video Frame Rate: 3 FPS ▾
Video Format: JPEG ▾

4.) Viewing a 6521 or 6522 on the lowest settings

Below is an example of the lowest settings on the 6521 and 6522 IP cameras

Streaming 1 Setting

Basic Mode Advanced Mode

Resolution: 176x144 ▾
Quality: Low ▾
Video Frame Rate: 3 FPS ▾
Video Format: JPEG ▾

Audio

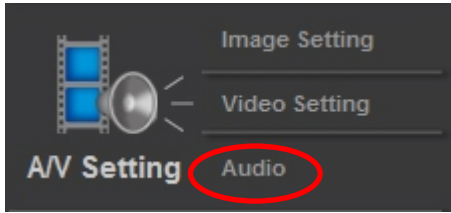

Audio:

Channel Vision IP Cameras support 2-way audio, allowing you to listen with an external microphone and speak through powered speakers using your PC, both internally in your network, as well as remotely over the internet. You can send audio from the IP camera to the PC you are connected to. You can also send audio from the PC to the IP camera. This audio output on the camera is located on the camera pigtail. You would need to connect to an amplifier, for example the A0240. To send audio from the PC to the IP camera, you need a standard microphone plugged into the computer, for example a 5104-MIC. You can also plug a microphone directly into the 6521, to feed the A0240 directly.

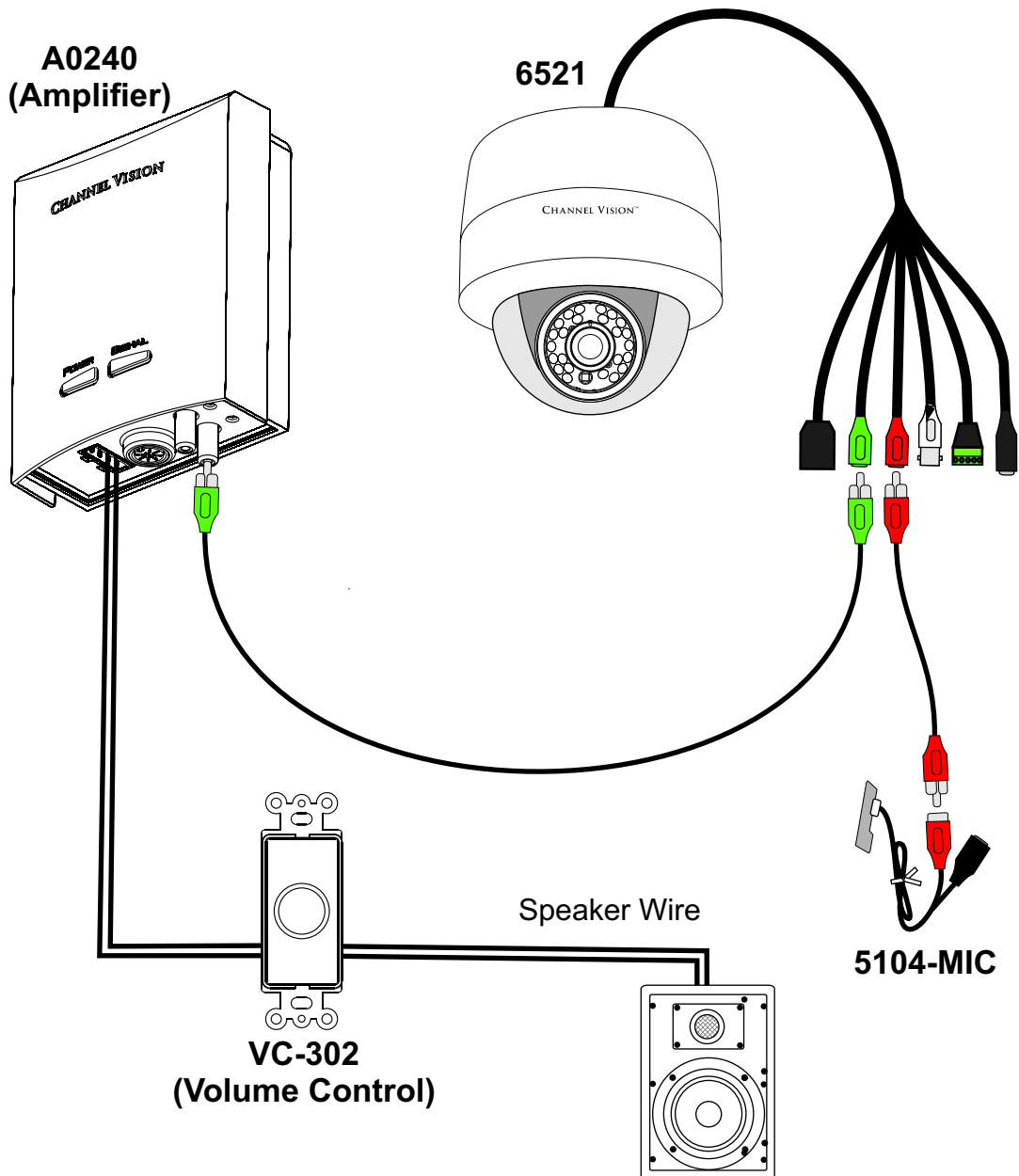

Audio/cont

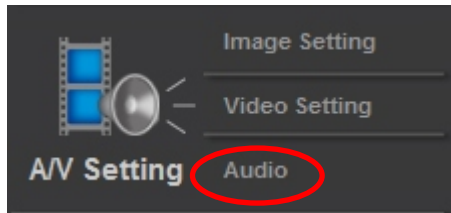

Audio: Below are instructions on how to enable audio on your IP camera.



Select "Enabled" to activate audio from the camera to your PC



Select "Chatting" to activate audio from your PC to the audio output of your IP camera

***While recording to an SD card on the IP camera, audio playback will be choppy.**

Event List

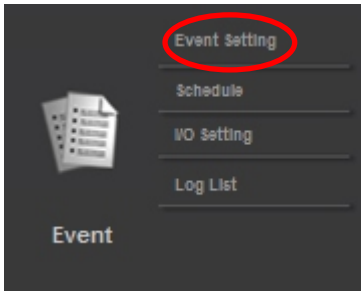

Event Setting

Area Setting:	Area 1	Area 2	Area 3
Sensitivity:	1(Low) ▾	5 ▾	5 ▾
<input type="checkbox"/> Area 1:	<input type="checkbox"/> E-mail <input type="checkbox"/> FTP <input type="checkbox"/> Out1		
<input type="checkbox"/> Area 2:	<input type="checkbox"/> E-mail <input type="checkbox"/> FTP <input type="checkbox"/> Out1		
<input type="checkbox"/> Area 3:	<input type="checkbox"/> E-mail <input type="checkbox"/> FTP <input type="checkbox"/> Out1		
Subject:	IP Camera Warning!		
Interval:	10 sec ▾	a period of time between every two motions detected.	
<input type="checkbox"/> Based on the <u>schedule</u>			
Record File			
File Format:	AVI File(with Record Time Setting) ▾		
Record Time Setting			
Pre Alarm:	5 sec ▾	Post Alarm:	5 sec ▾

1.) **Event Setting:** The purpose of this menu is to configure what the camera will do when an “event” is generated.

2.) Motion Detection

The 6521 & 6522 allow 3 areas of motion detection. (Area Setting) When motion is triggered, they can send the video, in the form of events to a specific mail address, transmit the live video to a remote FTP server, trigger a relay, and save events in the form of video to local SD card. (SD Card recording only available with the 6521 dome camera)

To set up the motion area, click “Area Setting”. Use the mouse to click and drag a box of the area you want to select. The same method is used for area 2 and area 3.

3.) **Record File Setting:** The 6521 & 6522 allow 3 different types of recording files.

A.) AVI File (With time stamp) This is the largest file size option to choose, but the video will be the highest quality available.

B.) JPEG (MJPEG) File (With time stamp) This is a smaller file size to choose, but is of lower quality than the AVI format.

C.) JPEG (MJPEG) Single file with interval setting.

Event List/cont.

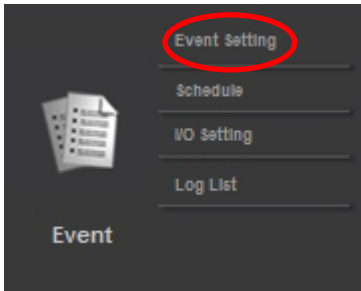

Event Setting

Area Setting:	Area 1	Area 2	Area 3
Sensitivity:	1(Low)	5	5

Record Time Setting

Pre Alarm: 5 sec Post Alarm: 5 sec

Network IP Check

IP Check: Enabled Disabled

IP Address:

Interval: 30 sec

IP Check: Save to SD card Apply

4.) Record Time Setting:

Pre Alarm and Post Alarm setups for record start and end time when motion is detected, or to trigger a relay. Note: Pre/Post Alarm record time based on record time setting and 6521 or 6522's built-in memory. The ability to store data is limited, so if the video quality is set very high, this will cause a drop in the recorded FPS. This will also decrease pre or post recording time.

5.) Network IP Check:

This option does two things. One, it checks your internet connection (Interval) to make sure your network connection has not been lost. Two, if your connection is lost, you can set this to automatically record to the SD card until it is full.

“IP Check” enables or disables this feature.

“IP Address” is what the camera will use to check if the internet is still working.

“Interval” is how often the camera will test your internet connection.

“IP Check” (lower option) has a box to check. When you check this box, you will record to your SD card upon network failure.

Schedule

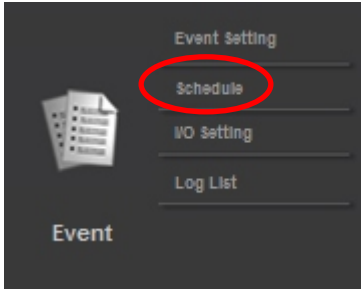

- 1.) **Schedule:** Complete schedule setup to tell the 6521 or 6522 when to record data.
- 2.) **Snapshot:** After enabling the snapshot function, user can select the storage location of the snapshot, the time of snapshot, and the file name of snapshot.

Schedule

All	0	1	2	3	4	5	6	7	8	9	10	11	12	13	14	15	16	17	18	19	20	21	22	23
Mon.																								
Tue.																								
Wed.																								
Thu.																								
Fri.																								
Sat.																								
Sun.																								

With schedule setup.

Snapshot

Enabled Disabled

Snapshot: E-mail FTP Save to SD card

Interval: Second(s) [1..50000]

File Name:

Click "Enabled" to enable snapshot.
 Select the E-mail, FTP, or Save to SD card option to enable.

Click the desired areas (boxes) to designate recording time.
 Green=record

I/O Setting

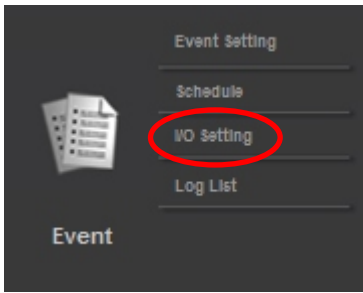

I/O Setting:

The 6521 & 6522 supports 1 input/1 output. When the input is triggered, it can send the video to a specific e-mail address, (only one receiver email is allowed) transmit the video to remote ftp server, trigger the relay, and save video to local SD card.

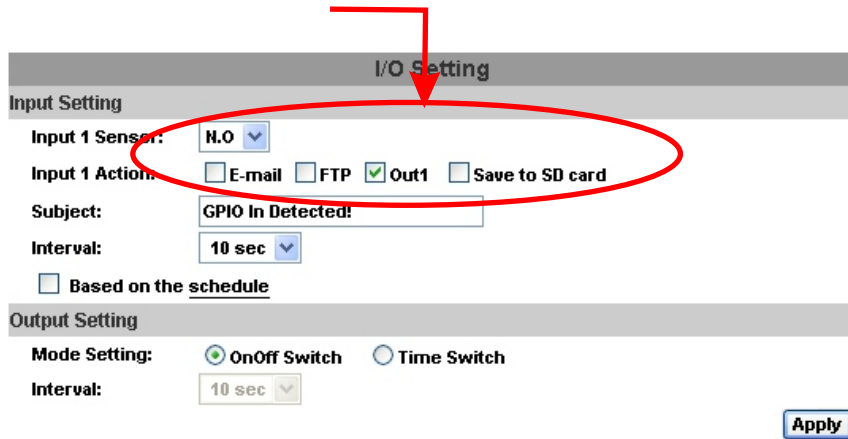

Alarm Input Setting: The GPIO I/O port input activates related functions when I/O input is triggered

GPIO Output Setting: The GPIO I/O port output activates a switch, slide switch or pan/tilt Module for use with any standard relay box

GPIO 0	ALARM INPUT
GPIO 1	Normal: 3.3V (The voltage differential from GPIO pin & GND) Active: 0V (GPIO 0 & GPIO1 link to PIN2 GND)
GPIO 2	ALARM OUTPUT
GPIO 3	Normal: 3.3V (The voltage differential from GPIO pin & GND) Active: 0V (GPIO 0 & GPIO1 link to PIN2 GND)

I/O Setting/cont

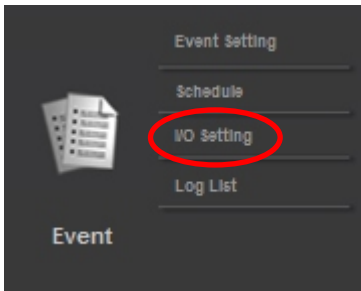

I/O Setting:

The 6521 & 6522 supports 1 input/1 output. When an input is triggered, it can send the video to a specific e-mail address, transmit the video to remote ftp server, trigger the relay, or save video to your SD card. (Note: 6521 dome offers an SD card option, 6522 does not)

GPIO INSTALLATION EXAMPLE 1: Floodlight

Trigger a normally off (Normally Open) alarm siren that activates when an event/motion occur at the COM terminal.



GPIO INSTALLATION EXAMPLE 2: Light Bulb

Trigger the normal on (Normally Closed) indoor light off when an event/motion occurs on the COM terminal.

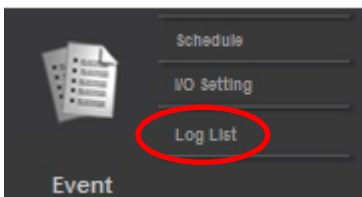
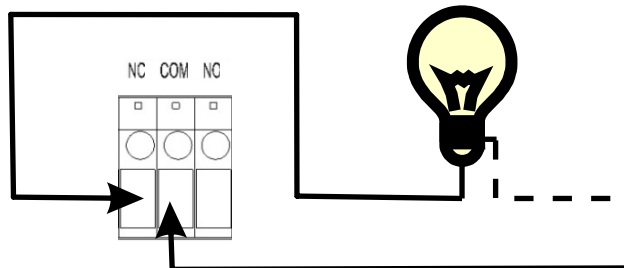

Log List

Log List: This menu provides access to the logs the 6521 or 6522 can create.

Log List	
System Logs	Logs
Motion Detection Logs	Logs
I/O Logs	Logs
All Logs	Logs

SD Card

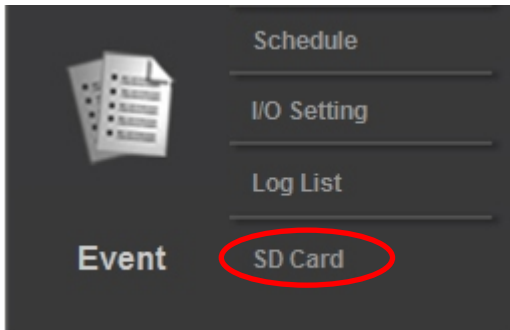

Recommended SD Cards

SanDisk 128M	Tracend 128M 80X
SanDisk 256M	Tracend 256M 80X
SanDisk 512M	Tracend 512M 80X
SanDisk 1G	Tracend 1G 80X
SanDisk 2G	Tracend 2G 80X
SanDisk 4G	Tracend 4G 80X

SD Card recording is only available on the 6521, Currently, this function is not supported on the 6522. Below is a picture showing the location of the SD card in the 6521 dome. Using the SD card could affect the frame rate of the video. Make sure the SD card is pushed into the slot completely.

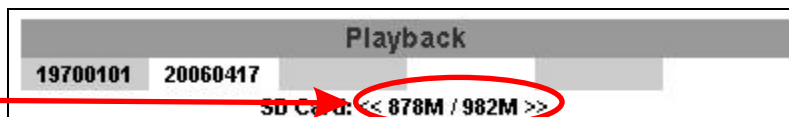
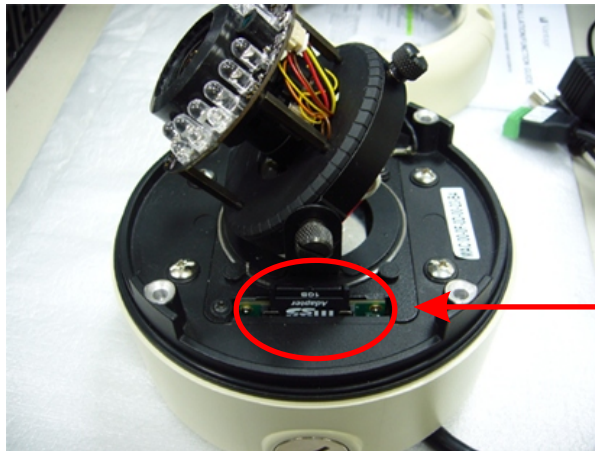

The capacity of the SD card is shown in the SD card menu. Below is a list of the video files recorded. The video format recorded to the SD card is AVI. Double click the video to open Windows Media Player and play the selected file. To delete the video, check it with the mouse, then click the Del. When the SD card is full, it will automatically delete the oldest video files.

2008/04/17			
Time	Video	Event Type	<input type="checkbox"/>
09:05:21	090522f.avi	Network Dis-connected	<input type="checkbox"/>
09:05:52	090552f.avi	Network Dis-connected	<input type="checkbox"/>
09:06:22	090622f.avi	Network Dis-connected	<input type="checkbox"/>
09:06:52	090652f.avi	Network Dis-connected	<input type="checkbox"/>
09:07:22	090722f.avi	Network Dis-connected	<input type="checkbox"/>
09:07:52	090752f.avi	Network Dis-connected	<input type="checkbox"/>
09:08:22	090822f.avi	Network Dis-connected	<input type="checkbox"/>
09:08:51	090851f.avi	Network Dis-connected	<input type="checkbox"/>
09:09:21	090921f.avi	Network Dis-connected	<input type="checkbox"/>
09:09:51	090951f.avi	Network Dis-connected	<input type="checkbox"/>

1 2 3 4 5

Port Forwarding

In order to view the IP camera from outside of your home or business network, port forwarding configuration will be required in your router.

Below are several points of reference regarding port forwarding.

1.) [Http://en.wikipedia.org/wiki/Port_forward](http://en.wikipedia.org/wiki/Port_forward)

The wikipedia page explains what port forwarding is, how it is used and what it's applications are.

****This website is not affiliated with Channel Vision.***

2.) [Http://screenshots.portforward.com/](http://screenshots.portforward.com/)

This website contains picture by picture walkthroughs on how to port forward most routers on the market.

****This website is not affiliated with Channel Vision.***

Port Forwarding LG Routers

In the example below, there is a 6521 running on port 8002 on the LAN.

- 1.) Add the IP information, including the desired port into the port forwarding tab of "advanced" in the router
- 2.) Check "Enable Port Forwarding"

Enable Port Forwarding

Description :	6521 IP Dome
Local IP :	192.168.2.64
Protocol :	Both ▾
Local Port :	8002
Public Port :	8002

3.) Click 'Add"

4.) Click "Select"

Current Port Forwarding Table :

NO.	Description	Local IP	Local Port	Type	Public Port	Select
1	6521 IP Dome	192.168.2.64	8002	BOTH	8002	<input type="checkbox"/>

5.) Select "Apply" to enable your new port forwarding rule

6521 Specifications

CPU:	ARM 9; 32 Bit RISC
DDR2:	256MB
Flash:	16MB
Image Sensor:	1/3" CMOS (2 Megapixel)
Sensitivity:	0 Lux (IR On)
DC Iris:	Yes
Lens Type:	Vari-focal 2.7 - 9mm
LED's:	18 IR LED (15 Meter Range)
I/O:	1 in / 1 Relay Out
Video Output:	BNC, Composite Video
Audio In:	1 Input, RCA
Audio Out:	1 Output, RCA
Power Over Ethernet:	Supported, Designed For 802.3af Standard, 47V Recommended
Power Consumption:	12vDC 480mA (IR on)
3 Axis Bracket:	Pan: 175° / Tilt 75° / Rotation 180°
Operating Temp.:	0° - 40° Celsius / 32° - 104° Fahrenheit
Dimensions:	141mm x 132mm / 5.5in x 5.2in
Ethernet:	10/ 100 Base-T
Network Protocol:	HTTP, TCP/ IP, SMTP, FTP, PPPoE, DHCP, DDNS, NTP, UPnP, 3GPP
Video Resolution:	1600x1200,1280x1024,1280x960,1280x720,800x600,640x480,320x240,176x144
Video Adjust:	Brightness, Contrast, Sharpness, BLC, Night Mode
Image Snapshot:	Yes
Full Screen Viewing:	Yes
Privacy Mask:	Yes, 3 different areas
Compression Format:	H.264/ JPEG (MJPEG)/ MPEG4 (3GPP only)
Video Bitrate Adjust:	CBR, VBR
Motion Detection:	Yes, 3 different areas
Triggered Actions:	Mail, FTP, Save to SD card,
Relay Pre/Post Alarm:	Yes, configurable
Security:	Password protection
Firmware Upgrade:	HTTP mode, can be upgraded remotely
Simultaneous Users:	Up to 10
Audio:	Yes, 2-way
Weatherproof Rating:	IP66

SD card management

Recording Trigger:	Motion Detection, IP check, Network Failure, (wire only) Schedule, Relay
Video Format:	AVI, JPEG
Video Playback:	Yes
Specific File Deletion:	Yes

System Requirements

OS:	Windows 2000, XP, Vista, 7
Browser:	Microsoft IE 6.0 or above
Suggested Hardware:	Intel Dual Core 1.66G,RAM: 1024MB, Graphic card: 128MB
Minimum Hardware:	Intel-C 2.8G, RAM: 512MB, Graphic card: 64MB

6522 Specifications

CPU:	ARM 9; 32 Bit RISC
DDR2:	256MB
Flash:	16MB
Image Sensor:	1/3.2" CMOS (2 Megapixel)
Sensitivity:	0 Lux (IR On)
DC Iris:	Yes
Lens Type:	Vari-focal 3.6 - 16mm
LED's:	35 IR LED (20 Meter Range)
I/O:	1 in / 1 Relay Out
Video Output:	BNC, Composite Video
Audio In:	1 Input, RCA
Audio Out:	1 Output, RCA
Power Over Ethernet:	Supported, Designed For 802.3af Standard, 47V Recommended
Power Consumption:	12vDC 500mA (IR on)
Operating Temp.:	0° - 40° Celsius / 32° - 104° Fahrenheit
Dimensions:	83mm(W) x 180mm(D) / 3.27in (W) x 7.09in(D)
Ethernet:	10/ 100 Base-T
Network Protocol:	HTTP, TCP/ IP, SMTP, FTP, PPPoE, DHCP, DDNS, NTP, UPnP, 3GPP
Video Resolution:	1600x1200,1280x1024,1280x960,1280x720,800x600,640x480,320x240,176x144
Video Adjust:	Brightness, Contrast, Sharpness, BLC, Night Mode
Image Snapshot:	Yes
Full Screen Viewing:	Yes
Privacy Mask:	Yes, 3 different areas
Compression Format:	H.264/ JPEG(MJPEG)/ MPEG4 (3GPP only)
Video Bitrate Adjust:	CBR, VBR
Motion Detection:	Yes, 3 different areas -
Triggered Actions:	Mail, FTP, Save to SD card,
Relay Pre/Post Alarm:	Yes, configurable
Security:	Password protection
Firmware Upgrade:	HTTP mode, can be upgraded remotely
Simultaneous Users:	Up to 10
Audio:	Yes, 2-way
Weatherproof Rating:	IP66

System Requirements

OS:	Windows 2000, XP, Vista, 7
Browser:	Microsoft IE 6.0 or above
Suggested Hardware:	Intel Dual Core 1.66G, RAM: 1024MB, Graphic card: 128MB
Minimum Hardware:	Intel-C 2.8G, RAM: 512MB, Graphic card: 64MB

*Specifications subject to change without notice.



1 Year Limited Warranty

Channel Vision Technology will repair or replace any defect in material or workmanship which occurs during normal use of this product with new or rebuilt parts, free of charge in the USA, for one year from the date of original purchase. This is a no hassle warranty with no mail in warranty card needed. This warranty does not cover damages in shipment, failures caused by other products not supplied by Channel Vision Technology, or failures due to accident, misuse, abuse, or alteration of the equipment. This warranty is extended only to the original purchaser, and a purchase receipt, invoice, or other proof of original purchase date will be required before warranty repairs are provided.

Mail in service can be obtained during the warranty period by calling (800) 840-0288 toll free. A Return Authorization number must be obtained in advance and can be marked on the outside of the shipping carton.

This warranty gives you specific legal rights and you may have other rights (which vary from state to state). If a problem with this product develops during or after the warranty period, please contact Channel Vision Technology, your dealer or any factory-authorized service center.

Channel Vision products are not intended for use in medical, lifesaving, life sustaining or critical environment applications. Channel Vision customers using or selling Channel Vision products for use in such applications do so at their own risk and agree to fully indemnify Channel Vision for any damages resulting from such improper use or sale.



234 Fischer Avenue, Costa Mesa, California 92626 USA
(714)424-6500 • (800)840-0288 • (714)424-6510 fax
email: techsupport@channelvision.com